



King William

804-CT~818-CT

Our King William fixtures offer you the chance to complete your totally gothic interior with an amazingly gothic series of chandeliers, pendants, ceiling, and wall mounted luminaires. We hand cast all the ornaments and loops here in our foundry ...to order. The lights may be made of aluminum, steel, or brass. Diffuser panels may be glass or acrylic. Metal finishes may be anything from antique brass to satin bronze aluminum. And lamping options can keep your lights maintenance-free for years while providing brightness you won't believe and energy savings you will love.

~King William Series~

- Chandelier:841-CHT-873-CHT
- Pendant:801-PT-817-PT
- Ceiling Mt:804-CT~818-CT
- Wall Mt:801-WT~813-WT
- S-Pendant:803-ST~815-ST

Mounting: Lightsmith fixtures mount to standard 4" octagon electrical boxes unless otherwise specified. All hardware and canopies supplied.

Listing and Warranty: Lightsmith fixtures are Underwriters Laboratories listed and carry a standard three year warranty against defects in materials and labor beginning at date of shipment.

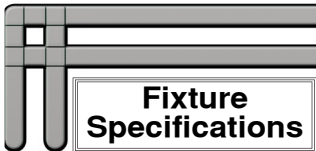

Fixture Specifications

8__-CT	~	DIFFUSER	~	METAL FINISH	~	VOLTAGE	~	NR	~	OPTIONS	~	MODIFICATIONS
(Example: 804-CT)		(Example: BGA-ECH)		(Example: ABB)		(120V) (277V) (347V)		STEM=S+Lgth (Example:S-96") CHAIN=C+Lgth (Example:C-96") NR=Not required		(Example: DIM, REM)		(Example: Custom Paint) Use "Notes" Box At Top To Explain Modifications

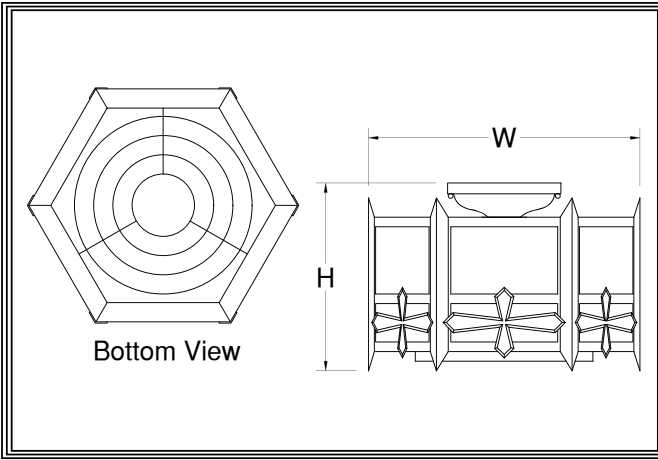

8__-CT	
Fixture Number	Job Type
Job Name	

Notes~Modifications

	Fixture Number	Dimensions	Lamping	Weight	Options
LED	<input type="checkbox"/> 804-CT	16w x 10h	3-11wCLED (3576 lm)	9 lbs	REM, SPR ** L123
	<input type="checkbox"/> 805-CT	18w x 10h	3-13wCLED (4230 lm)	11 lbs	
INCANDESCENT	<input type="checkbox"/> 816-CT	16w x 10h	3-60wA (2400 lm)	7 lbs	N75 N100
	<input type="checkbox"/> 818-CT	18w x 10h	3-75wA (3600 lm)	9 lbs	
FLUORESCENT	<input type="checkbox"/>				

~Single Circuit Standard Wiring~

**All LED Fixtures

DIFFUSER	<input type="checkbox"/> BGA: Beige Alabaster Acrylic	<input type="checkbox"/> GRA: Green Edge Acrylic	<input type="checkbox"/> ECH: Etched*
	<input type="checkbox"/> NHA: Natural Horn Acrylic	<input type="checkbox"/> EGA: Earth Green Acrylic	*Etched option creates a matte, non-glossy finish on one side of the diffuser. (Example: WOA-ECH)
	<input type="checkbox"/> WHA: White Alabaster Acrylic	<input type="checkbox"/> DGA: Deep Gold Acrylic	
	<input type="checkbox"/> HNA: Honey Alabaster Acrylic	<input type="checkbox"/> SOG: Streaked Opal Glass	
	<input type="checkbox"/> WOA: White Opal Acrylic	<input type="checkbox"/> WOG: White Opal Glass	

	SOLID BRASS FINISHES	PAINTED METAL FINISHES	ALUMINUM FINISHES	STAINLESS STEEL FINISHES
METAL FINISH	<input type="checkbox"/> ABB: Antique Brass	<input type="checkbox"/> DGP: Dark Green	<input type="checkbox"/> SAA: Satin Aluminum	<input type="checkbox"/> NA
	<input type="checkbox"/> SBB: Satin Brass	<input type="checkbox"/> VGP: Verde Green	<input type="checkbox"/> SNA: Satin Nickel	<input type="checkbox"/>
	<input type="checkbox"/> PBB: Polished Brass	<input type="checkbox"/> CGP: Charcoal Gray	<input type="checkbox"/> PAA: Polished Aluminum	<input type="checkbox"/>
	<input type="checkbox"/> ANB: Antique Nickel	<input type="checkbox"/> MBP: Medium Bronze	<input type="checkbox"/> BBA: Burnished Bronze	<input type="checkbox"/>
	<input type="checkbox"/> SNB: Satin Nickel	<input type="checkbox"/> SBP: Satin Black	<input type="checkbox"/> RNA: Red Naval Bronze	<input type="checkbox"/>
	<input type="checkbox"/> PNB: Polished Nickel	<input type="checkbox"/> DBP: Dark Bronze	<input type="checkbox"/> SGA: Satin Gold	<input type="checkbox"/>
	<input type="checkbox"/> AZB: Antique Bronze	<input type="checkbox"/> LBP: Light Bronze	<input type="checkbox"/> SBA: Satin Bronze	<input type="checkbox"/>
	<input type="checkbox"/> SZB: Satin Bronze	<input type="checkbox"/> MGP: Medium Gold	<input type="checkbox"/> ORA: Oil Rubbed Bronze	<input type="checkbox"/>
	<input type="checkbox"/> PZB: Polished Bronze	<input type="checkbox"/> SCP: Sponged Copper	<input type="checkbox"/> SCA: Satin Copper	<input type="checkbox"/>
	<input type="checkbox"/> CSB: Custom Brass*	<input type="checkbox"/> CSP: Custom Paint*	<input type="checkbox"/> CSA: Custom Aluminum*	<input type="checkbox"/>

OPTIONS	<input type="checkbox"/> N75: 75wPar30 Downlight	<input type="checkbox"/> L123: 1-23wCLED Downlight	<input type="checkbox"/> SPR: Surge protector
	<input type="checkbox"/> N100: 100wPar30 Downlight	<input type="checkbox"/>	<input type="checkbox"/>
	<input type="checkbox"/> DIM: Dimming Driver (Std)	<input type="checkbox"/>	<input type="checkbox"/>
	<input type="checkbox"/> REM: Remote Emer.Ballast	<input type="checkbox"/>	<input type="checkbox"/>
	<input type="checkbox"/>	<input type="checkbox"/>	<input type="checkbox"/>