



Monroe

303-ST~315-ST

Our Monroe fixtures have been a popular item with Lightsmith customers for many years. They are available in a variety of finishes and diffusers; but we consistently make them from solid antique brass and real streaked opal glass...just like the pendant photo. These are beautiful lanterns, symmetrical and bright. Though these lights are still very traditional in every way on the outside, you may order some amazing lamping options for the inside. For example, if you don't want to change bulbs for the next twenty years; order out LED option. Enjoy the spare time...go fishing.

~Monroe Series~

Chandelier:341-CHT~373-CHT

Pendant:301-PT~317-PT

Ceiling Mount:304-CT~317-CT

Wall Mount:301-WT~313-WT

S-Pendant:303-ST~315-ST

Mounting: Lightsmith fixtures mount to standard 4" octagon electrical boxes unless otherwise specified. All hardware and canopies supplied.

Listing and Warranty: Lightsmith fixtures are Underwriters Laboratories listed and carry a standard three year warranty against defects in materials and labor beginning at date of shipment.



Fixture Specifications

3 -ST
FIXTURE NUMBER
(Example: 303-ST)

~ **DIFFUSER**
(Example: BGA-ECH)

~ **METAL FINISH**
(Example: ABB)

~ **VOLTAGE**
 (120V)
 (277V)
 (347V)

~ **STEM=**S+Lgth
(Example: S-96")
CHAIN=C+Lgth
(Example: C-96")
NR=Not required

~ **OPTIONS**
(Example: DIM, REM)

~ **MODIFICATIONS**
(Example: Custom Paint)
Use "Notes" Box At Top To Explain Modifications

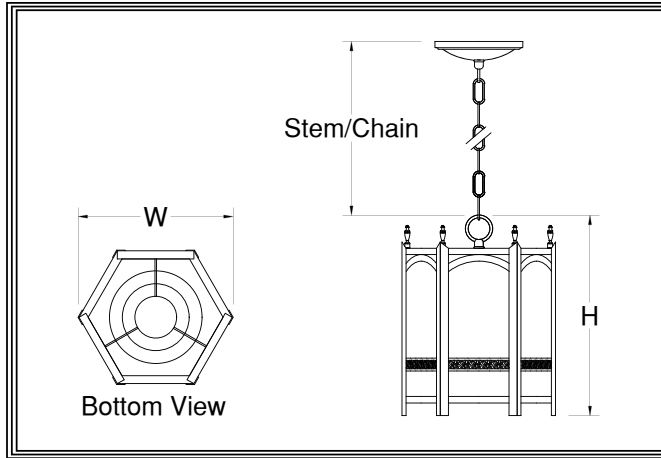

3 -ST

Fixture Number Job Type

Job Name

Notes~Modifications

	Fixture Number	Dimensions	Lamping	Weight	Stem/Chain	Options
LED	<input type="checkbox"/> 303-ST	12w x 14h	2-13wCLED/1-23wCLED	14 lbs	3' Std	L213,L138
	<input type="checkbox"/> 304-ST	14w x 14h	3-13wCLED/1-38wCLED	17 lbs	3' Std	L313,L152 DALI,REM,FUS**
INCANDESCENT	<input type="checkbox"/> 312-ST	12w x 14h	3-60wA/1-200wBR40	11 lbs	3' Std	N300
	<input type="checkbox"/> 314-ST	14w x 14h	3-100wA/1-250wP38	14 lbs	3' Std	N500
FLUORESCENT	<input type="checkbox"/> 313-ST	12w x 14h	2-32wCFT/2-32wCFTdn	13 lbs	3' Std	L213
	<input type="checkbox"/> 315-ST	14w x 14h	2-42wCFT/2-42wCFTdn	16 lbs	3' Std	L313 DIM,REM,FUS*

~Two Circuits Standard Wiring~

*All Fluorescent Fixtures
**All LED Fixtures

DIFFUSER	DIFFUSER	DIFFUSER
<input type="checkbox"/> BGA: Beige Alabaster Acrylic	<input type="checkbox"/> GRA: Green Edge Acrylic	<input type="checkbox"/> ECH: Etched*
<input type="checkbox"/> NHA: Natural Horn Acrylic	<input type="checkbox"/> EGA: Earth Green Acrylic	*Etched option creates a matte, non-glossy finish on one side of the diffuser. (Example: WOA-ECH)
<input type="checkbox"/> WHA: White Alabaster Acrylic	<input type="checkbox"/> DGA: Deep Gold Acrylic	
<input type="checkbox"/> HNA: Honey Alabaster Acrylic	<input type="checkbox"/> SOG: Streaked Opal Glass	
<input type="checkbox"/> WOA: White Opal Acrylic	<input type="checkbox"/> WOG: White Opal Glass	

METAL FINISH	SOLID BRASS FINISHES	PAINTED METAL FINISHES	ALUMINUM FINISHES	STAINLESS STEEL FINISHES
<input type="checkbox"/> ABB: Antique Brass	<input type="checkbox"/> DGP: Dark Green	<input type="checkbox"/> SAA: Satin Aluminum	<input type="checkbox"/> SSS: Satin	
<input type="checkbox"/> SBB: Satin Brass	<input type="checkbox"/> VGP: Verde Green	<input type="checkbox"/> SNA: Satin Nickel	<input type="checkbox"/> DSS: Distressed	
<input type="checkbox"/> PBB: Polished Brass	<input type="checkbox"/> CGP: Charcoal Gray	<input type="checkbox"/> PAA: Polished Aluminum	<input type="checkbox"/> PSS: Polished	
<input type="checkbox"/> ANB: Antique Nickel	<input type="checkbox"/> MBP: Medium Bronze	<input type="checkbox"/> BBA: Burnished Bronze	<input type="checkbox"/> HSS: Hammered	
<input type="checkbox"/> SNB: Satin Nickel	<input type="checkbox"/> SBP: Satin Black	<input type="checkbox"/> RNA: Red Naval Bronze	<input type="checkbox"/>	
<input type="checkbox"/> PNB: Polished Nickel	<input type="checkbox"/> DBP: Dark Bronze	<input type="checkbox"/> SGA: Satin Gold	<input type="checkbox"/>	
<input type="checkbox"/> AZB: Antique Bronze	<input type="checkbox"/> LBP: Light Bronze	<input type="checkbox"/> SBA: Satin Bronze	<input type="checkbox"/>	
<input type="checkbox"/> SZB: Satin Bronze	<input type="checkbox"/> MGP: Medium Gold	<input type="checkbox"/> ORA: Oil Rubbed Bronze	<input type="checkbox"/>	
<input type="checkbox"/> PZB: Polished Bronze	<input type="checkbox"/> SCP: Sponged Copper	<input type="checkbox"/> SCA: Satin Copper	<input type="checkbox"/>	
<input type="checkbox"/> CSB: Custom Brass*	<input type="checkbox"/> CSP: Custom Paint*	<input type="checkbox"/> CSA: Custom Aluminum*	<input type="checkbox"/> CSS: Custom SS*	

OPTIONS	OPTIONS	OPTIONS
<input type="checkbox"/> N300: 300wPar56 Downlight	<input type="checkbox"/> L213: 2-13wCLED Uplight	<input type="checkbox"/> FUS: Fusing
<input type="checkbox"/> N500: 500wPar56 Downlight	<input type="checkbox"/> L313: 3-13wCLED Uplight	<input type="checkbox"/> DALI: Dali dimming LED
<input type="checkbox"/> DIM: Dimming Ballast	<input type="checkbox"/> L138: 1-38wCLED Downlight	<input type="checkbox"/> C: "C" Arch Option
<input type="checkbox"/> REM: Remote Emer.Ballast	<input type="checkbox"/> L152: 1-52wCLED Downlight	<input type="checkbox"/> G: "G" Arch Option
<input type="checkbox"/>	<input type="checkbox"/>	<input type="checkbox"/>