



Biscoe

1601-WT~1613-WT

Our Biscoe fixtures are exacting replicas of an historic Gruber Bothers lantern made in New York in the first half of the 1900's. They feature the same heavy-framed channel corner staves and thick ornamental side castings that Gruber was famous for. But we have made a few interior improvements that push these fixtures into the 21st century. Though we still offer an upgraded incandescent interior, most orders are for LED modular interior clusters. And most metal finishes for these lights are done in a super durable exterior grade powdercoat, not wet lacquer. So old becomes new...only better!

~Biscoe Series~

Chandelier:1641-CHT~1673-CHT

Pendant:1601-PT~1617-PT

Ceiling Mount:1604-CT~1617-CT

Wall Mount:1601-WT~1613-WT

S-Pendant:1603-ST~1615-ST

Mounting: Lightsmith fixtures mount to standard 4" octagon electrical boxes unless otherwise specified. All hardware and canopies supplied.

Listing and Warranty: Lightsmith fixtures are Underwriters Laboratories listed and carry a standard three year warranty against defects in materials and labor beginning at date of shipment.



Fixture Specifications

16__-WT

FIXTURE NUMBER
(Example: 1608-WT)

DIFFUSER
(Example: BGA-ECH)

METAL FINISH
(Example: ABB)

VOLTAGE
 (120V)
 (277V)
 (347V)

NR

STEM=S+Lgth
(Example:S-96")
 CHAIN=C+Lgth
(Example:C-96")
 NR=Not required

OPTIONS
(Example:DIM,REM)

MODIFICATIONS
(Example:Custom Paint*)
 Use "Notes" Box At Top To Explain Modifications

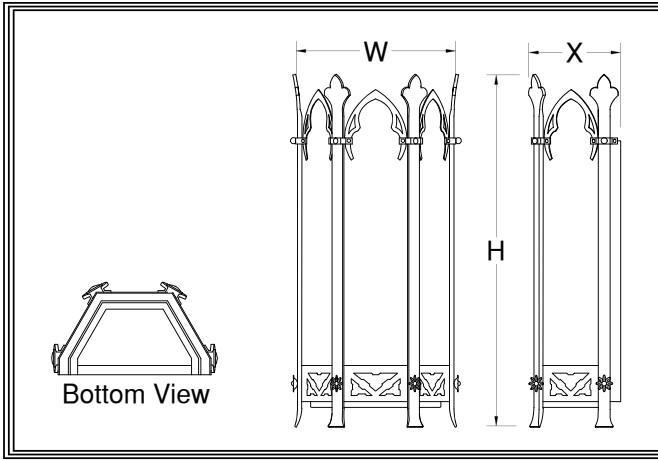

16__-WT

Fixture Number

Job Type

Job Name

Notes~Modifications

| | Fixture Number | Dimensions | Lamping | Weight | Options |
|--------------|----------------------------------|----------------|---------------------|--------|---------------------|
| LED | <input type="checkbox"/> 1601-WT | 8w x 17h x 4x* | 2-13wLLED (2820 lm) | 6 lbs | TPL,REM,SPR |
| | <input type="checkbox"/> 1602-WT | 10w x 21h x 5x | 3-13wLLED (4230 lm) | 8 lbs | TPL,IEM,SPR |
| | <input type="checkbox"/> 1603-WT | 12w x 25h x 6x | 4-13wLLED (5640 lm) | 10 lbs | TPL,IEM,SPR |
| INCANDESCENT | <input type="checkbox"/> 1608-WT | 8w x 17h x 4x* | 2-60wA (1600 lm) | 4 lbs | WLM |
| | <input type="checkbox"/> 1610-WT | 10w x 21h x 5x | 3-60wA (2400 lm) | 6 lbs | WLM |
| | <input type="checkbox"/> 1612-WT | 12w x 25h x 6x | 4-60wA (3200 lm) | 8 lbs | WLM |
| FLUORESCENT | <input type="checkbox"/> 1609-WT | 8w x 17h x 4x* | 2-18wCFQ (2400 lm) | 5 lbs | TPL,REM,FUS |
| | <input type="checkbox"/> 1611-WT | 10w x 21h x 5x | 2-26wCFQ (3600 lm) | 7 lbs | TPL,IEM,FUS |
| | <input type="checkbox"/> 1613-WT | 12w x 25h x 6x | 2-FT36w (5800 lm) | 9 lbs | TPL,IEM,FUS DIM* |

*ADA Fixture

~Single Circuit Standard Wiring~

*All Fluorescent Fixtures

| | | | |
|----------|---|---|--|
| DIFFUSER | <input type="checkbox"/> BGA: Beige Alabaster Acrylic | <input type="checkbox"/> GRA: Green Edge Acrylic | <input type="checkbox"/> ECH: Etched* |
| | <input type="checkbox"/> NHA: Natural Horn Acrylic | <input type="checkbox"/> EGA: Earth Green Acrylic | *Etched option creates a matte, non-glossy finish on one side of the diffuser. (Example:WOA-ECH) |
| | <input type="checkbox"/> WHA: White Alabaster Acrylic | <input type="checkbox"/> DGA: Deep Gold Acrylic | |
| | <input type="checkbox"/> HNA: Honey Alabaster Acrylic | <input type="checkbox"/> SOG: Streaked Opal Glass | |
| | <input type="checkbox"/> WOA: White Opal Acrylic | <input type="checkbox"/> WOG: White Opal Glass | |

| | SOLID BRASS FINISHES | PAINTED METAL FINISHES | ALUMINUM FINISHES | STAINLESS STEEL FINISHES |
|--------------|---|--|---|--|
| METAL FINISH | <input type="checkbox"/> ABB: Antique Brass | <input type="checkbox"/> DGP: Dark Green | <input type="checkbox"/> SAA: Satin Aluminum | <input type="checkbox"/> SSS: Satin |
| | <input type="checkbox"/> SBB: Satin Brass | <input type="checkbox"/> VGP: Verde Green | <input type="checkbox"/> SNA: Satin Nickel | <input type="checkbox"/> DSS: Distressed |
| | <input type="checkbox"/> PBB: Polished Brass | <input type="checkbox"/> CGP: Charcoal Gray | <input type="checkbox"/> PAA: Polished Aluminum | <input type="checkbox"/> PSS: Polished |
| | <input type="checkbox"/> ANB: Antique Nickel | <input type="checkbox"/> MBP: Medium Bronze | <input type="checkbox"/> BBA: Burnished Bronze | <input type="checkbox"/> HSS: Hammered |
| | <input type="checkbox"/> SNB: Satin Nickel | <input type="checkbox"/> SBP: Satin Black | <input type="checkbox"/> RNA: Red Naval Bronze | <input type="checkbox"/> |
| | <input type="checkbox"/> PNB: Polished Nickel | <input type="checkbox"/> DBP: Dark Bronze | <input type="checkbox"/> SGA: Satin Gold | <input type="checkbox"/> |
| | <input type="checkbox"/> AZB: Antique Bronze | <input type="checkbox"/> LBP: Light Bronze | <input type="checkbox"/> SBA: Satin Bronze | <input type="checkbox"/> |
| | <input type="checkbox"/> SZB: Satin Bronze | <input type="checkbox"/> MGP: Medium Gold | <input type="checkbox"/> ORA: Oil Rubbed Bronze | <input type="checkbox"/> |
| | <input type="checkbox"/> PZB: Polished Bronze | <input type="checkbox"/> SCP: Sponged Copper | <input type="checkbox"/> SCA: Satin Copper | <input type="checkbox"/> |
| | <input type="checkbox"/> CSB: Custom Brass* | <input type="checkbox"/> CSP: Custom Paint* | <input type="checkbox"/> CSA: Custom Aluminum* | <input type="checkbox"/> |
| | <input type="checkbox"/> | | | <input type="checkbox"/> |
| | <input type="checkbox"/> | | | <input type="checkbox"/> |
| | <input type="checkbox"/> | | | <input type="checkbox"/> |
| | <input type="checkbox"/> | | | <input type="checkbox"/> |

| | | | |
|---------|---|---|---|
| OPTIONS | <input type="checkbox"/> DIM: Dimming Ballast | <input type="checkbox"/> WLM: Wet Location Mounting | <input type="checkbox"/> FUS: Fusing |
| | <input type="checkbox"/> REM: Remote Emer.Ballast | <input type="checkbox"/> TPL: Top Lens | <input type="checkbox"/> IEM: Integral Emer.Ballast |
| | <input type="checkbox"/> | | <input type="checkbox"/> SPR: Surge Protection |
| | <input type="checkbox"/> | | |
| | <input type="checkbox"/> | | |
| | <input type="checkbox"/> | | |