



Madison

501-WC~513-WC

Our Madison fixtures are one of the shop's earliest designs dating all the way back to 1988. They are really an economy of materials for us. Those brass tube swirls at top were actually "leftovers" from our chandelier orders that we didn't want to throw away. After searching for the right way to incorporate them into a pendant fixture, the Madison was born. The staves are a multi-layered solid brass extrusion we used in framing some very upscale architectural metal projects. Together, those two salvaged materials have produced one of our nicest, and most-imitated products.

~Madison Series~

Chandelier:541-CHC~573-CHC

Pendant:501-PC~517-PC

Ceiling Mount:504-CC~517-CC

Wall Mount:501-WC~513-WC

S-Pendant:503-SC~515-SC

Mounting: Lightsmith fixtures mount to standard 4" octagon electrical boxes unless otherwise specified. All hardware and canopies supplied.

Listing and Warranty: Lightsmith fixtures are Underwriters Laboratories listed and carry a standard three year warranty against defects in materials and labor beginning at date of shipment.



Fixture Specifications

5 -WC
FIXTURE NUMBER
(Example: 508-WC)

~ **DIFFUSER**
(Example: BGA-ECH)

~ **METAL FINISH**
(Example: ABB)

~ **VOLTAGE**
 (120V)
 (277V)
 (347V)

~ **NR**
STEM=S+Lgth
(Example:S-96")
CHAIN=C+Lgth
(Example:C-96")
NR=Not required

~ **OPTIONS**
(Example: DIM, REM)

~ **MODIFICATIONS**
(Example: Custom Paint)
Use "Notes" Box At Top To Explain Modifications

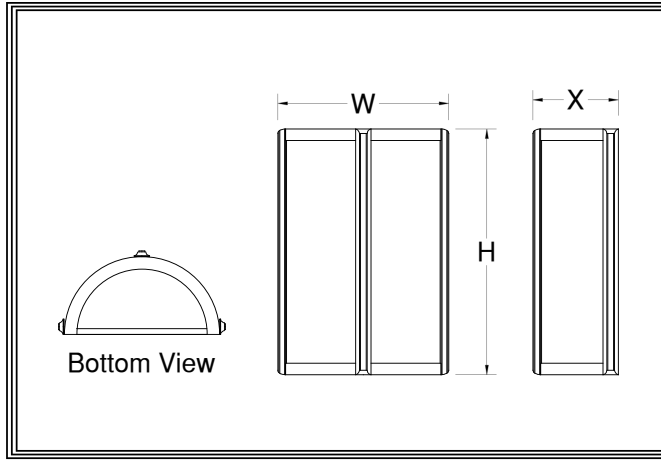

5 -WC

Fixture Number

Job Type

Job Name

Notes~Modifications

	Fixture Number	Dimensions	Lamping	Weight	Options
LED	<input type="checkbox"/> 501-WC	9w x 14h x 4x*	2-13wLLED	7 lbs	WLM,TPL
	<input type="checkbox"/> 502-WC	11w x 16h x 5x	4-13wLLED	11 lbs	WLM,TPL,IEM
	<input type="checkbox"/> 503-WC	13w x 20h x 6x	6-13wLLED	14 lbs	WLM,TPL,IEM DALI,REM,FUS**
INCANDESCENT	<input type="checkbox"/> 508-WC	9w x 14h x 4x*	2-60wA	5 lbs	WLM
	<input type="checkbox"/> 510-WC	11w x 16h x 5x	3-60wA	8 lbs	WLM
	<input type="checkbox"/> 512-WC	13w x 20h x 6x	4-60wA	11 lbs	WLM
FLUORESCENT	<input type="checkbox"/> 509-WC	9w x 14h x 4x*	2-18wCFQ	7 lbs	WLM,TPL
	<input type="checkbox"/> 511-WC	11w x 16h x 5x	2-26wCFQ	10 lbs	WLM,TPL,IEM
	<input type="checkbox"/> 513-WC	13w x 20h x 6x	2-FT36w	13 lbs	WLM,TPL,IEM DIM,REM,FUS*

*ADA Fixture

~Single Circuit Standard Wiring~

*All Fluorescent Fixtures

**All LED Fixtures

DIFFUSER	<input type="checkbox"/> BGA: Beige Alabaster Acrylic	<input type="checkbox"/> GRA: Green Edge Acrylic	<input type="checkbox"/> ECH: Etched*
	<input type="checkbox"/> NHA: Natural Horn Acrylic	<input type="checkbox"/> EGA: Earth Green Acrylic	*Etched option creates a matte, non-glossy finish on one side of the diffuser. (Example: WOA-ECH)
	<input type="checkbox"/> WHA: White Alabaster Acrylic	<input type="checkbox"/> DGA: Deep Gold Acrylic	
	<input type="checkbox"/> HNA: Honey Alabaster Acrylic	<input type="checkbox"/> SBA: Sea Blue Acrylic	
	<input type="checkbox"/> WOA: White Opal Acrylic	<input type="checkbox"/> PHA: Purple Haze Acrylic	

	SOLID BRASS FINISHES	PAINTED METAL FINISHES	ALUMINUM FINISHES	STAINLESS STEEL FINISHES
METAL FINISH	<input type="checkbox"/> ABB: Antique Brass	<input type="checkbox"/> DGP: Dark Green	<input type="checkbox"/> SAA: Satin Aluminum	<input type="checkbox"/> SSS: Satin
	<input type="checkbox"/> SBB: Satin Brass	<input type="checkbox"/> VGP: Verde Green	<input type="checkbox"/> SNA: Satin Nickel	<input type="checkbox"/> DSS: Distressed
	<input type="checkbox"/> PBB: Polished Brass	<input type="checkbox"/> CGP: Charcoal Gray	<input type="checkbox"/> PAA: Polished Aluminum	<input type="checkbox"/> PSS: Polished
	<input type="checkbox"/> ANB: Antique Nickel	<input type="checkbox"/> MBP: Medium Bronze	<input type="checkbox"/> BBA: Burnished Bronze	<input type="checkbox"/> HSS: Hammered
	<input type="checkbox"/> SNB: Satin Nickel	<input type="checkbox"/> SBP: Satin Black	<input type="checkbox"/> RNA: Red Naval Bronze	<input type="checkbox"/>
	<input type="checkbox"/> PNB: Polished Nickel	<input type="checkbox"/> DBP: Dark Bronze	<input type="checkbox"/> SGA: Satin Gold	<input type="checkbox"/>
	<input type="checkbox"/> AZB: Antique Bronze	<input type="checkbox"/> LBP: Light Bronze	<input type="checkbox"/> SBA: Satin Bronze	<input type="checkbox"/>
	<input type="checkbox"/> SZB: Satin Bronze	<input type="checkbox"/> MGP: Medium Gold	<input type="checkbox"/> ORA: Oil Rubbed Bronze	<input type="checkbox"/>
	<input type="checkbox"/> PZB: Polished Bronze	<input type="checkbox"/> SCP: Sponged Copper	<input type="checkbox"/> SCA: Satin Copper	<input type="checkbox"/>
	<input type="checkbox"/> CSB: Custom Brass*	<input type="checkbox"/> CSP: Custom Paint*	<input type="checkbox"/> CSA: Custom Aluminum*	<input type="checkbox"/> CSS: Custom SS*

OPTIONS	<input type="checkbox"/> DIM: Dimming Ballast	<input type="checkbox"/> WLM: Wet Location Mounting	<input type="checkbox"/> FUS: Fusing
	<input type="checkbox"/> REM: Remote Emer. Ballast	<input type="checkbox"/> TPL: Top Lens	<input type="checkbox"/> IEM: Integral Emer. Ballast
	<input type="checkbox"/>	<input type="checkbox"/>	<input type="checkbox"/> DALI: Dali dimming LED
	<input type="checkbox"/>	<input type="checkbox"/>	<input type="checkbox"/>
	<input type="checkbox"/>	<input type="checkbox"/>	<input type="checkbox"/>
	<input type="checkbox"/>	<input type="checkbox"/>	<input type="checkbox"/>