

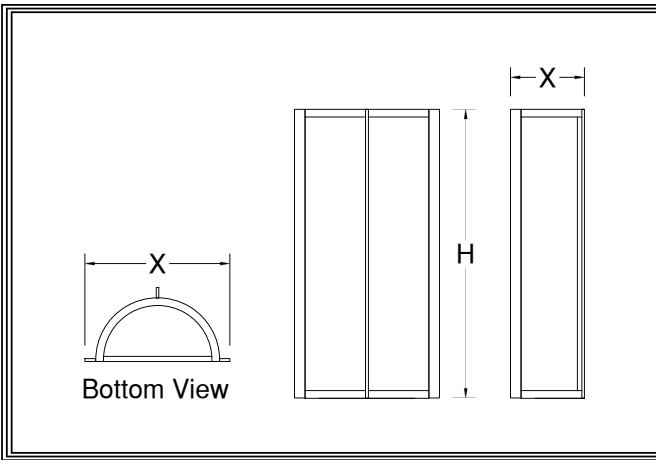

Nash



20__-WC

Fixture Number

Job Type

Job Name

Notes~Modifications

2001-WC~2013-WC

Our Nash series fixtures are seamless extruded cylinders when ordered in white. They are surrounded on either end by hand spun trim rings. Four aluminum fins join the rings end to end in the pendant version for a very stable and fine-detailed look. These fixtures look just right in contemporary settings, but with the right finish, can blend equally well into classic auditoriums. Because there is very little metal or wood blocking the light output, these are very brilliant fixtures. Just right for places needing lots of light. And our LED lamping options will make them all the brighter and long lasting.

~Nash Series~

Chandelier: 2041-CHC~2073-CHC

Pendant: 2001-PC~2017-PC

Ceiling Mount: 2002-CC~2013-CC

Wall Mount: 2001-WC~2013-WC

S-Pendant: 2002-SC~2013-SC

Mounting: Lightsmith fixtures mount to standard 4" octagon electrical boxes unless otherwise specified. All hardware and canopies supplied.

Listing and Warranty: Lightsmith fixtures are Underwriters Laboratories listed and carry a standard three year warranty against defects in materials and labor beginning at date of shipment.



Fixture Specifications

20__-WC

FIXTURE NUMBER
(Example: 2008-WC)

~ DIFFUSER
(Example: BGA-ECH)

~ METAL FINISH
(Example: ABB)

~ VOLTAGE
 (120V)
 (277V)
 (347V)

~ NR
STEM=S+Lgth
(Example: S-96")
CHAIN=C+Lgth
(Example: C-96")
NR=Not required

~ OPTIONS
(Example: DIM,REM)

~ MODIFICATIONS
(Example: Custom Paint)
Use "Notes" Box At Top To Explain Modifications

	Fixture Number	Dimensions	Lamping	Weight	Options
LED	<input type="checkbox"/> 2001-WC	10w x 14h x 4x*	2-13wLLED	4 lbs	L211,WLM,TPL
	<input type="checkbox"/> 2002-WC	12w x 16h x 6x	3-13wLLED	6 lbs	L213,WLM,TPL,IEM
	<input type="checkbox"/> 2003-WC	14w x 20h x 7x	4-13wLLED	8 lbs	L223,WLM,TPL,IEM DALI,REM,FUS**
INCANDESCENT	<input type="checkbox"/> 2008-WC	10w x 14h x 4x*	2-60wA	3 lbs	WLM
	<input type="checkbox"/> 2010-WC	12w x 16h x 6x	3-60wA	5 lbs	WLM
	<input type="checkbox"/> 2012-WC	14w x 20h x 7x	4-60wA	7 lbs	WLM
FLUORESCENT	<input type="checkbox"/> 2009-WC	10w x 14h x 4x*	2-18wCFQ	4 lbs	WLM,TPL
	<input type="checkbox"/> 2011-WC	12w x 16h x 6x	2-26wCFQ	6 lbs	WLM,TPL,IEM
	<input type="checkbox"/> 2013-WC	14w x 20h x 7x	2-FT36w	8 lbs	WLM,TPL,IEM DIM,REM,FUS*

*ADA Fixture

~Single Circuit Standard Wiring~

*All Fluorescent Fixtures
**All LED Fixtures

DIFFUSER	<input type="checkbox"/> BGA: Beige Alabaster Acrylic	<input type="checkbox"/> GRA: Green Edge Acrylic	<input type="checkbox"/> ECH: Etched*
	<input type="checkbox"/> NHA: Natural Horn Acrylic	<input type="checkbox"/> EGA: Earth Green Acrylic	*Etched option creates a matte, non-glossy finish on one side of the diffuser. (Example: WOA-ECH)
	<input type="checkbox"/> WHA: White Alabaster Acrylic	<input type="checkbox"/> DGA: Deep Gold Acrylic	
	<input type="checkbox"/> HNA: Honey Alabaster Acrylic	<input type="checkbox"/> SBA: Sea Blue Acrylic	
	<input type="checkbox"/> WOA: White Opal Acrylic	<input type="checkbox"/> PHA: Purple Haze Acrylic	

	SOLID BRASS FINISHES	PAINTED METAL FINISHES	ALUMINUM FINISHES	STAINLESS STEEL FINISHES
METAL FINISH	<input type="checkbox"/> ABB: Antique Brass	<input type="checkbox"/> DGP: Dark Green	<input type="checkbox"/> SAA: Satin Aluminum	<input type="checkbox"/> SSS: Satin
	<input type="checkbox"/> SBB: Satin Brass	<input type="checkbox"/> VGP: Verde Green	<input type="checkbox"/> SNA: Satin Nickel	<input type="checkbox"/> DSS: Distressed
	<input type="checkbox"/> PBB: Polished Brass	<input type="checkbox"/> CGP: Charcoal Gray	<input type="checkbox"/> PAA: Polished Aluminum	<input type="checkbox"/> PSS: Polished
	<input type="checkbox"/> ANB: Antique Nickel	<input type="checkbox"/> MBP: Medium Bronze	<input type="checkbox"/> BBA: Burnished Bronze	<input type="checkbox"/> HSS: Hammered
	<input type="checkbox"/> SNB: Satin Nickel	<input type="checkbox"/> SBP: Satin Black	<input type="checkbox"/> RNA: Red Naval Bronze	<input type="checkbox"/>
	<input type="checkbox"/> PNB: Polished Nickel	<input type="checkbox"/> DBP: Dark Bronze	<input type="checkbox"/> SGA: Satin Gold	<input type="checkbox"/>
	<input type="checkbox"/> AZB: Antique Bronze	<input type="checkbox"/> LBP: Light Bronze	<input type="checkbox"/> SBA: Satin Bronze	<input type="checkbox"/>
	<input type="checkbox"/> SZB: Satin Bronze	<input type="checkbox"/> MGP: Medium Gold	<input type="checkbox"/> ORA: Oil Rubbed Bronze	<input type="checkbox"/>
	<input type="checkbox"/> PZB: Polished Bronze	<input type="checkbox"/> SCP: Sponged Copper	<input type="checkbox"/> SCA: Satin Copper	<input type="checkbox"/>
	<input type="checkbox"/> CSB: Custom Brass*	<input type="checkbox"/> CSP: Custom Paint*	<input type="checkbox"/> CSA: Custom Aluminum*	<input type="checkbox"/>
	<input type="checkbox"/>			<input type="checkbox"/>
	<input type="checkbox"/>			<input type="checkbox"/>
	<input type="checkbox"/>			<input type="checkbox"/>
	<input type="checkbox"/>			<input type="checkbox"/>

OPTIONS	<input type="checkbox"/> L211: 2-11wCLED Up/Dnlight	<input type="checkbox"/> WLM: Wet Location Mounting	<input type="checkbox"/> FUS: Fusing
	<input type="checkbox"/> L213: 2-13wCLED Up/Dnlight	<input type="checkbox"/> TPL: Top Lens	<input type="checkbox"/> IEM: Integral Emer.Ballast
	<input type="checkbox"/> L223: 2-23wCLED Up/Dnlight	<input type="checkbox"/>	<input type="checkbox"/> DALI: Dali dimming LED
	<input type="checkbox"/> DIM: Dimming Ballast	<input type="checkbox"/>	<input type="checkbox"/>
	<input type="checkbox"/> REM: Remote Emer.Ballast	<input type="checkbox"/>	<input type="checkbox"/>
	<input type="checkbox"/>	<input type="checkbox"/>	<input type="checkbox"/>