



# Albemarle

## 1603-CC~1615-CC

Our Albemarle fixtures feature straight-bodied acrylic cylinders with three metal crosses mounted mid way around the pendant styles. Hand spun trim rings are painted, satin finished, polished, or hammered to suit the needs of the auditorium. The clean lines and symbolism of this fixture make it extremely popular within a wide variety of sanctuaries. No less important are the lampings we offer with these lights. Our incandescent versions are OK if you can reach them for easy lamp replacement; but if the pendants are mounted in difficult-to-reach areas, our CFL and LED interiors will last many years.

### ~Albemarle Series~

Chandelier:1641-CHC~1673-CHC

Pendant:1601-PC~1617-PC

Ceiling Mount:1603-CC~1615-CC

Wall Mount:1601-WC~1613-WC

S-Pendant:1603-SC~1615-SC

**Mounting:** Lightsmith fixtures mount to standard 4" octagon electrical boxes unless otherwise specified. All hardware and canopies supplied.

**Listing and Warranty:** Lightsmith fixtures are Underwriters Laboratories listed and carry a standard three year warranty against defects in materials and labor beginning at date of shipment.



## Fixture Specifications

16 -CC	~		~		~	NR	~		~			
FIXTURE NUMBER (Example: 1603-CC)		DIFFUSER (Example: BGA-ECH)		METAL FINISH (Example: ABB)		VOLTAGE <input type="checkbox"/> (120V) <input type="checkbox"/> (277V) <input type="checkbox"/> (347V)		STEM=S+Lgth (Example: S-96") CHAIN=C+Lgth (Example: C-96") NR=Not required		OPTIONS (Example: DIM, REM)		MODIFICATIONS (Example: Custom Paint) Use "Notes" Box At Top To Explain Modifications

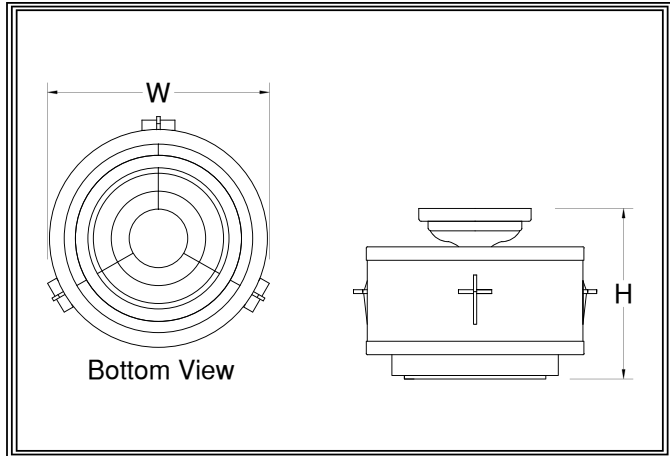

16 -CC     

Fixture Number      Job Type

Job Name

Notes~Modifications

	Fixture Number	Dimensions	Lamping	Weight	Stem/Chain	Options
LED	<input type="checkbox"/> 1603-CC	12w x 10h	3-11wCLED	6 lbs	NR	L123
	<input type="checkbox"/> 1604-CC	14w x 10h	3-13wCLED	7 lbs	NR	L123 DALI,REM,FUS**
INCANDESCENT	<input type="checkbox"/> 1612-CC	12w x 10h	3-60wA	4 lbs	NR	N75
	<input type="checkbox"/> 1614-CC	14w x 10h	3-75wA	5 lbs	NR	N100
FLUORESCENT	<input type="checkbox"/> 1613-CC	12w x 10h	2-26wCFT	5 lbs	NR	L123
	<input type="checkbox"/> 1615-CC	14w x 10h	2-42wCFT	6 lbs	NR	L123 DIM,REM,FUS*

~Two Circuits Standard Wiring~

\*All Fluorescent Fixtures  
\*\*All LED Fixtures

DIFFUSER	<input type="checkbox"/> BGA: Beige Alabaster Acrylic	<input type="checkbox"/> GRA: Green Edge Acrylic	<input type="checkbox"/> ECH: Etched*
	<input type="checkbox"/> NHA: Natural Horn Acrylic	<input type="checkbox"/> EGA: Earth Green Acrylic	*Etched option creates a matte, non-glossy finish on one side of the diffuser. (Example: WOA-ECH)
	<input type="checkbox"/> WHA: White Alabaster Acrylic	<input type="checkbox"/> DGA: Deep Gold Acrylic	
	<input type="checkbox"/> HNA: Honey Alabaster Acrylic	<input type="checkbox"/> SBA: Sea Blue Acrylic	
	<input type="checkbox"/> WOA: White Opal Acrylic	<input type="checkbox"/> PHA: Purple Haze Acrylic	

	SOLID BRASS FINISHES	PAINTED METAL FINISHES	ALUMINUM FINISHES	STAINLESS STEEL FINISHES
METAL FINISH	<input type="checkbox"/> ABB: Antique Brass	<input type="checkbox"/> DGP: Dark Green	<input type="checkbox"/> SAA: Satin Aluminum	<input type="checkbox"/> SSS: Satin
	<input type="checkbox"/> SBB: Satin Brass	<input type="checkbox"/> VGP: Verde Green	<input type="checkbox"/> SNA: Satin Nickel	<input type="checkbox"/> DSS: Distressed
	<input type="checkbox"/> PBB: Polished Brass	<input type="checkbox"/> CGP: Charcoal Gray	<input type="checkbox"/> PAA: Polished Aluminum	<input type="checkbox"/> PSS: Polished
	<input type="checkbox"/> ANB: Antique Nickel	<input type="checkbox"/> MBP: Medium Bronze	<input type="checkbox"/> BBA: Burnished Bronze	<input type="checkbox"/> HSS: Hammered
	<input type="checkbox"/> SNB: Satin Nickel	<input type="checkbox"/> SBP: Satin Black	<input type="checkbox"/> RNA: Red Naval Bronze	<input type="checkbox"/>
	<input type="checkbox"/> PNB: Polished Nickel	<input type="checkbox"/> DBP: Dark Bronze	<input type="checkbox"/> SGA: Satin Gold	<input type="checkbox"/>
	<input type="checkbox"/> AZB: Antique Bronze	<input type="checkbox"/> LBP: Light Bronze	<input type="checkbox"/> SBA: Satin Bronze	<input type="checkbox"/>
	<input type="checkbox"/> SZB: Satin Bronze	<input type="checkbox"/> MGP: Medium Gold	<input type="checkbox"/> ORA: Oil Rubbed Bronze	<input type="checkbox"/>
	<input type="checkbox"/> PZB: Polished Bronze	<input type="checkbox"/> SCP: Sponged Copper	<input type="checkbox"/> SCA: Satin Copper	<input type="checkbox"/>
	<input type="checkbox"/> CSB: Custom Brass*	<input type="checkbox"/> CSP: Custom Paint*	<input type="checkbox"/> CSA: Custom Aluminum*	<input type="checkbox"/>
				<input type="checkbox"/> CSS: Custom SS*

OPTIONS	<input type="checkbox"/> N75: 75wPar30 Downlight	<input type="checkbox"/> L123: 1-23wCLED Downlight	<input type="checkbox"/> FUS: Fusing
	<input type="checkbox"/> N100: 100wPar30 Downlight	<input type="checkbox"/>	<input type="checkbox"/> DALI: Dali dimming LED
	<input type="checkbox"/> DIM: Dimming Ballast	<input type="checkbox"/>	<input type="checkbox"/>
	<input type="checkbox"/> REM: Remote Emer. Ballast	<input type="checkbox"/>	<input type="checkbox"/>
	<input type="checkbox"/>	<input type="checkbox"/>	<input type="checkbox"/>