



Monticello

101-WC~115-WC

Our Monticello fixtures combine the warmth and versatility of wood with the glimmer of satin and polished metals to produce a sturdy and attractive blend of materials. These fixtures are great complements to spaces with wood ceilings or walls. We frequently match existing wood stains to the stains on our hardwood battens for seamless integration of fixture to room. You will see white acrylic and medium oak staves in the pendant photo, but the fixture could just as well be honey alabaster and oil rubbed bronze for auditoriums with deeper color configurations. Great, long lasting lampings available, too.

~Monticello Series~

- Chandelier: 141-CHC~173-CHC
- Pendant: 101-PC~117-PC
- Ceiling Mount: 104-CC~117-CC
- Wall Mount: 101-WC~115-WC
- S-Pendant: 103-SC~115-SC

Mounting: Lightsmith fixtures mount to standard 4" octagon electrical boxes unless otherwise specified. All hardware and canopies supplied.

Listing and Warranty: Lightsmith fixtures are Underwriters Laboratories listed and carry a standard three year warranty against defects in materials and labor beginning at date of shipment.



Fixture Specifications

1 -WC	~		~		~		~		~	NR	~		~	
FIXTURE NUMBER (Example: 101-WC)		DIFFUSER (Example: BGA-ECH)		WOOD FINISH (Example: MOK)		METAL FINISH (Example: ABB)		VOLTAGE <input type="checkbox"/> (120V) <input type="checkbox"/> (277V) <input type="checkbox"/> (347V)		STEM=S+Lgth (Example: S-96") CHAIN=C+Lgth (Example: C-96") NR=Not required		OPTIONS (Example: DIM, REM)		MODIFICATIONS (Example: Custom Paint) Use "Notes" Box At Top To Explain Modifications

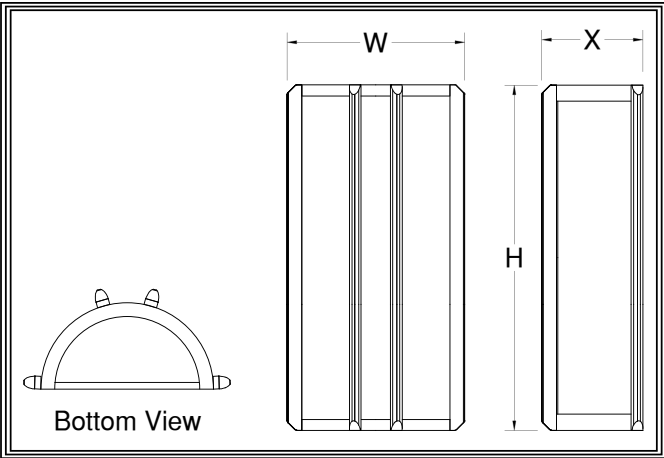

1 -WC	
Fixture Number	Job Type
Job Name	
Notes~Modifications	

	Fixture Number	Dimensions	Lamping	Weight	Options
LED	<input type="checkbox"/> 101-WC	10w x 14h x 5x	2-13wLLED	5 lbs	WLM, TPL
	<input type="checkbox"/> 102-WC	12w x 16h x 6x	4-13wLLED	6 lbs	WLM, TPL, IEM
	<input type="checkbox"/> 103-WC	14w x 20h x 7x	6-13wLLED	8 lbs	WLM, TPL, IEM DALI, REM, FUS**
INCANDESCENT	<input type="checkbox"/> 110-WC	10w x 14h x 5x	2-60wA	3 lbs	WLM
	<input type="checkbox"/> 112-WC	12w x 16h x 6x	3-60wA	4 lbs	WLM
	<input type="checkbox"/> 114-WC	14w x 20h x 7x	4-60wA	6 lbs	WLM
FLUORESCENT	<input type="checkbox"/> 111-WC	10w x 14h x 5x	2-18wCFQ	4 lbs	WLM, TPL
	<input type="checkbox"/> 113-WC	12w x 16h x 6x	2-26wCFQ	5 lbs	WLM, TPL, IEM
	<input type="checkbox"/> 115-WC	14w x 20h x 7x	2-FT36w	7 lbs	WLM, TPL, IEM DIM, REM, FUS*

~Single Circuit Standard Wiring~
 *All Fluorescent Fixtures
 **All LED Fixtures

DIFFUSER	<input type="checkbox"/> BGA: Beige Alabaster Acrylic	<input type="checkbox"/> GRA: Green Edge Acrylic	<input type="checkbox"/> ECH: Etched*
	<input type="checkbox"/> NHA: Natural Horn Acrylic	<input type="checkbox"/> HNA: Honey Alabaster Acrylic	<i>*Etched option creates a matte, non-glossy finish on one side of the diffuser. (Example: WOA-ECH)</i>
	<input type="checkbox"/> WHA: White Alabaster Acrylic	<input type="checkbox"/> WOA: White Opal Acrylic	
WOOD	<input type="checkbox"/> LOK: Light Oak	<input type="checkbox"/> LCH: Light Cherry	
	<input type="checkbox"/> MOK: Medium Oak	<input type="checkbox"/> MCH: Medium Cherry	
	<input type="checkbox"/> DOK: Dark Oak	<input type="checkbox"/> DCH: Dark Cherry	

	SOLID BRASS FINISHES	PAINTED METAL FINISHES	ALUMINUM FINISHES	STAINLESS STEEL FINISHES
METAL FINISH	<input type="checkbox"/> ABB: Antique Brass	<input type="checkbox"/> DGP: Dark Green	<input type="checkbox"/> SAA: Satin Aluminum	<input type="checkbox"/> SSS: Satin
	<input type="checkbox"/> SBB: Satin Brass	<input type="checkbox"/> VGP: Verde Green	<input type="checkbox"/> SNA: Satin Nickel	<input type="checkbox"/> DSS: Distressed
	<input type="checkbox"/> PBB: Polished Brass	<input type="checkbox"/> CGP: Charcoal Gray	<input type="checkbox"/> PAA: Polished Aluminum	<input type="checkbox"/> PSS: Polished
	<input type="checkbox"/> ANB: Antique Nickel	<input type="checkbox"/> MBP: Medium Bronze	<input type="checkbox"/> BBA: Burnished Bronze	<input type="checkbox"/> HSS: Hammered
	<input type="checkbox"/> SNB: Satin Nickel	<input type="checkbox"/> SBP: Satin Black	<input type="checkbox"/> RNA: Red Naval Bronze	<input type="checkbox"/>
	<input type="checkbox"/> PNB: Polished Nickel	<input type="checkbox"/> DBP: Dark Bronze	<input type="checkbox"/> SGA: Satin Gold	<input type="checkbox"/>
	<input type="checkbox"/> AZB: Antique Bronze	<input type="checkbox"/> LBP: Light Bronze	<input type="checkbox"/> SBA: Satin Bronze	<input type="checkbox"/>
	<input type="checkbox"/> SZB: Satin Bronze	<input type="checkbox"/> MGP: Medium Gold	<input type="checkbox"/> ORA: Oil Rubbed Bronze	<input type="checkbox"/>
	<input type="checkbox"/> PZB: Polished Bronze	<input type="checkbox"/> SCP: Sponged Copper	<input type="checkbox"/> SCA: Satin Copper	<input type="checkbox"/>
	<input type="checkbox"/> CSB: Custom Brass*	<input type="checkbox"/> CSP: Custom Paint*	<input type="checkbox"/> CSA: Custom Aluminum*	<input type="checkbox"/> CSS: Custom SS*
				<input type="checkbox"/>
				<input type="checkbox"/>

OPTIONS	<input type="checkbox"/> DIM: Dimming Ballast	<input type="checkbox"/> WLM: Wet Location Mounting	<input type="checkbox"/> FUS: Fusing
	<input type="checkbox"/> REM: Remote Emer. Ballast	<input type="checkbox"/> TPL: Top Lens	<input type="checkbox"/> IEM: Integral Emer. Ballast
	<input type="checkbox"/>		<input type="checkbox"/> DALI: Dali dimming LED
	<input type="checkbox"/>		<input type="checkbox"/>
	<input type="checkbox"/>		<input type="checkbox"/>
	<input type="checkbox"/>		<input type="checkbox"/>