



Blake

CL-9800~CL-9808

Our Blake fixtures are lean metal staves attached to hand spun metal trim rings. Interior light passes through a translucent acrylic cylinder lens to produce a smooth and inviting glow, while downlight options in the pendants of the series can throw lots of footcandles to the floor below for very comfortable reading levels. The combination of interior and down light, make for a totally functional luminaire in even the dimmest of places. Be sure to try our CFL and LED options. They will make life much easier for a busy maintenance staff. Blake is good to look at and easy to keep.

~Blake Series~

- Chandelier: CH-9800~CH-9811
- Pendant: PD-9800~PD-9831
- Ceiling Mt: CL-9800~CL-9808
- Wall Mt: SC-9800~SC-9811
- Bollard: BL-9800~BL-9811

Mounting: Lightsmith fixtures mount to standard 4" octagon electrical boxes unless otherwise specified. All hardware and canopies supplied.

Listing and Warranty: Lightsmith fixtures are Underwriters Laboratories listed and carry a standard three year warranty against defects in materials and labor beginning at date of shipment.

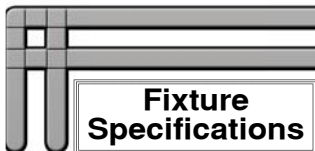

CL-98 _____ ~ _____ ~ _____ ~ _____ ~ **NR** ~ _____ ~ _____

FIXTURE NUMBER (Example: CL-9802) DIFFUSER (Example: BGA-ECH) METAL FINISH (Example: ABB) VOLTAGE (120V, 277V, 347V) STEM=S+Lgth (Example: S-96") CHAIN=C+Lgth (Example: C-96") NR=Not required OPTIONS (Example: DIM, REM) MODIFICATIONS (Example: Custom Paint*) Use "Notes" Box At Top To Explain Modifications

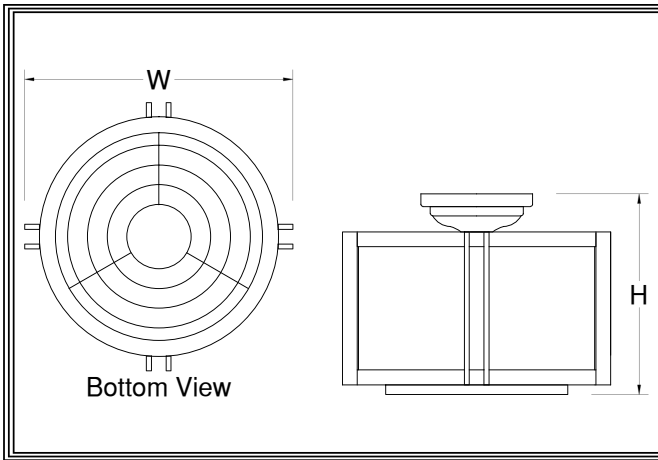

CL-98 _____ _____

Fixture Number Job Type

Job Name

Notes~Modifications

	Fixture Number	Dimensions	Lamping	Weight	Options
LED	<input type="checkbox"/> CL-9806	12w x 8h	3-11wCLED	9 lbs	L123
	<input type="checkbox"/> CL-9807	14w x 8h	3-13wCLED	11 lbs	L123
	<input type="checkbox"/> CL-9808	14w x 10h	3-23wCLED	16 lbs	DALI, REM, FUS**
INCANDESCENT	<input type="checkbox"/> CL-9800	12w x 8h	3-60wA	6 lbs	N75
	<input type="checkbox"/> CL-9801	14w x 8h	3-75wA	8 lbs	N100
	<input type="checkbox"/> CL-9802	14w x 10h	3-100wA	12 lbs	N100
FLUORESCENT	<input type="checkbox"/> CL-9803	12w x 8h	2-26wCFT	8 lbs	L123
	<input type="checkbox"/> CL-9804	14w x 8h	2-32wCFT	10 lbs	L123
	<input type="checkbox"/> CL-9805	14w x 10h	2-42wCFT	15 lbs	DIM, REM, FUS*

~Single Circuit Standard Wiring~

*All Fluorescent Fixtures
**All LED Fixtures

DIFFUSER	<input type="checkbox"/> BGA: Beige Alabaster Acrylic	<input type="checkbox"/> GRA: Green Edge Acrylic	<input type="checkbox"/> ECH: Etched*
	<input type="checkbox"/> NHA: Natural Horn Acrylic	<input type="checkbox"/> EGA: Earth Green Acrylic	*Etched option creates a matte, non-glossy finish on one side of the diffuser. (Example: WOA-ECH)
	<input type="checkbox"/> WHA: White Alabaster Acrylic	<input type="checkbox"/> DGA: Deep Gold Acrylic	
	<input type="checkbox"/> HNA: Honey Alabaster Acrylic	<input type="checkbox"/> SBA: Sea Blue Acrylic	
	<input type="checkbox"/> WOA: White Opal Acrylic	<input type="checkbox"/> PHA: Purple Haze Acrylic	

	SOLID BRASS FINISHES	PAINTED METAL FINISHES	ALUMINUM FINISHES	STAINLESS STEEL FINISHES
METAL FINISH	<input type="checkbox"/> ABB: Antique Brass	<input type="checkbox"/> DGP: Dark Green	<input type="checkbox"/> SAA: Satin Aluminum	<input type="checkbox"/> SSS: Satin
	<input type="checkbox"/> SBB: Satin Brass	<input type="checkbox"/> VGP: Verde Green	<input type="checkbox"/> SNA: Satin Nickel	<input type="checkbox"/> DSS: Distressed
	<input type="checkbox"/> PBB: Polished Brass	<input type="checkbox"/> CGP: Charcoal Gray	<input type="checkbox"/> PAA: Polished Aluminum	<input type="checkbox"/> PSS: Polished
	<input type="checkbox"/> ANB: Antique Nickel	<input type="checkbox"/> MBP: Medium Bronze	<input type="checkbox"/> BBA: Burnished Bronze	<input type="checkbox"/> HSS: Hammered
	<input type="checkbox"/> SNB: Satin Nickel	<input type="checkbox"/> SBP: Satin Black	<input type="checkbox"/> RNA: Red Naval Bronze	<input type="checkbox"/>
	<input type="checkbox"/> PNB: Polished Nickel	<input type="checkbox"/> DBP: Dark Bronze	<input type="checkbox"/> SGA: Satin Gold	<input type="checkbox"/>
	<input type="checkbox"/> AZB: Antique Bronze	<input type="checkbox"/> LBP: Light Bronze	<input type="checkbox"/> SBA: Satin Bronze	<input type="checkbox"/>
	<input type="checkbox"/> SZB: Satin Bronze	<input type="checkbox"/> MGP: Medium Gold	<input type="checkbox"/> ORA: Oil Rubbed Bronze	<input type="checkbox"/>
	<input type="checkbox"/> PZB: Polished Bronze	<input type="checkbox"/> SCP: Sponged Copper	<input type="checkbox"/> SCA: Satin Copper	<input type="checkbox"/>
	<input type="checkbox"/> CSB: Custom Brass*	<input type="checkbox"/> CSP: Custom Paint*	<input type="checkbox"/> CSA: Custom Aluminum*	<input type="checkbox"/> CSS: Custom SS*

OPTIONS	<input type="checkbox"/> N75: 75wPar30 Downlight	<input type="checkbox"/> L123: 1-23wCLED Downlight	<input type="checkbox"/> FUS: Fusing
	<input type="checkbox"/> N100: 100wPar30 Downlight	<input type="checkbox"/>	<input type="checkbox"/> DALI: Dali dimming LED
	<input type="checkbox"/> DIM: Dimming Ballast	<input type="checkbox"/>	<input type="checkbox"/>
	<input type="checkbox"/> REM: Remote Emer. Ballast	<input type="checkbox"/>	<input type="checkbox"/>
	<input type="checkbox"/>	<input type="checkbox"/>	<input type="checkbox"/>