



Abaco

SC-9600~SC-9611

Our Abaco fixtures are simple and attractive bowl designs. They feature a large two-step spun upper trim ring that supports a smooth bowl. We offer stem options with the Abaco pendants that allow four angled supports as well as four straight stems coming down into the trim ring...very nice options for differing geometries of an auditorium. And our finishes are as complete as you could imagine, ranging from solid satin brass to polished aluminum. The acrylics we use are just as nice, and our lamping options give you the opportunity to install trouble free LED lighting.

~Abaco Series~

- Chandelier: CH-9600~CH-9611
- Pendant: PD-9600~PD-9631
- Ceiling Mount: CL-9600~CL-9608
- Wall Mount: SC-9600~SC-9611
- Bollard: BL-9600~BL-9611

Mounting: Lightsmith fixtures mount to standard 4" octagon electrical boxes unless otherwise specified. All hardware and canopies supplied.

Listing and Warranty: Lightsmith fixtures are Underwriters Laboratories listed and carry a standard three year warranty against defects in materials and labor beginning at date of shipment.



Fixture Specifications

SC-96 _____ ~ _____ ~ _____ ~ _____ ~ NR ~ _____ ~ _____

FIXTURE NUMBER (Example: SC-9600) DIFFUSER (Example: BGA-ECH) METAL FINISH (Example: ABB) VOLTAGE (120V, 277V, 347V) STEM=S+Lgth (Example: S-96"), CHAIN=C+Lgth (Example: C-96"), NR=Not required OPTIONS (Example: DIM, IEM) MODIFICATIONS (Example: Custom Paint*) Use "Notes" Box At Top To Explain Modifications

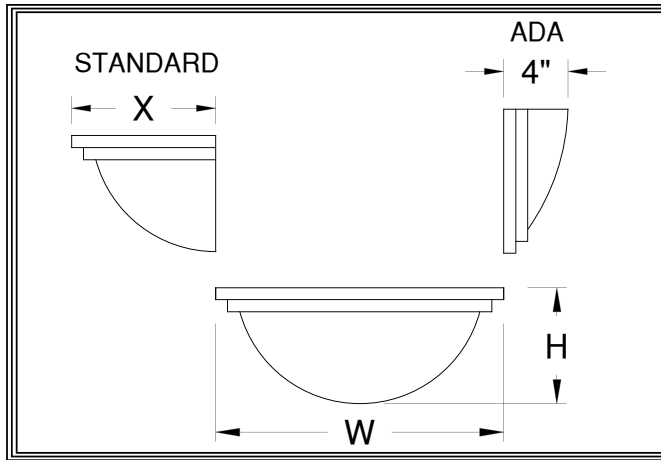

SC-96 _____ _____

Fixture Number Job Type

Job Name

Notes~Modifications

	Fixture Number	Dimensions	Lamping	Weight	Options
LED	<input type="checkbox"/> SC-9609	16w x 6h x 4x*	2-13wLLED (2820 lumens)	6 lbs	L211,TPL
	<input type="checkbox"/> SC-9610	20w x 8h x 10x	3-13wLLED (4230 lumens)	8 lbs	L213,IEM,TPL
	<input type="checkbox"/> SC-9611	24w x 10h x 12x	4-13wLLED (5640 lumens)	10 lbs	L223,IEM,TPL REM,SPR**
INCANDESCENT	<input type="checkbox"/> SC-9600	16w x 6h x 4x*	2-60wA (1600 lumens)	3 lbs	TPL
	<input type="checkbox"/> SC-9601	20w x 8h x 10x	3-60wA (2400 lumens)	5 lbs	TPL
	<input type="checkbox"/> SC-9602	24w x 10h x 12x	4-60wA (3200 lumens)	7 lbs	TPL
FLUORESCENT	<input type="checkbox"/>				

*ADA Fixture

~Single Circuit Standard Wiring~

**All LED Fixtures

DIFFUSER	<input type="checkbox"/> BGA: Beige Alabaster Acrylic	<input type="checkbox"/> GRA: Green Edge Acrylic	<input type="checkbox"/> ECH: Etched*
	<input type="checkbox"/> NHA: Natural Horn Acrylic	<input type="checkbox"/> EGA: Earth Green Acrylic	*Etched option creates a matte, non-glossy finish on one side of the diffuser. (Example: WOA-ECH)
	<input type="checkbox"/> WHA: White Alabaster Acrylic	<input type="checkbox"/> DGA: Deep Gold Acrylic	
	<input type="checkbox"/> HNA: Honey Alabaster Acrylic	<input type="checkbox"/> SBA: Sea Blue Acrylic	
	<input type="checkbox"/> WOA: White Opal Acrylic	<input type="checkbox"/> PHA: Purple Haze Acrylic	

	SOLID BRASS FINISHES	PAINTED METAL FINISHES	ALUMINUM FINISHES	STAINLESS STEEL FINISHES
METAL FINISH	<input type="checkbox"/> ABB: Antique Brass	<input type="checkbox"/> DGP: Dark Green	<input type="checkbox"/> SAA: Satin Aluminum	<input type="checkbox"/> SSS: Satin
	<input type="checkbox"/> SBB: Satin Brass	<input type="checkbox"/> VGP: Verde Green	<input type="checkbox"/> SNA: Satin Nickel	<input type="checkbox"/> DSS: Distressed
	<input type="checkbox"/> PBB: Polished Brass	<input type="checkbox"/> CGP: Charcoal Gray	<input type="checkbox"/> PAA: Polished Aluminum	<input type="checkbox"/> PSS: Polished
	<input type="checkbox"/> ANB: Antique Nickel	<input type="checkbox"/> MBP: Medium Bronze	<input type="checkbox"/> BBA: Burnished Bronze	<input type="checkbox"/> HSS: Hammered
	<input type="checkbox"/> SNB: Satin Nickel	<input type="checkbox"/> SBP: Satin Black	<input type="checkbox"/> RNA: Red Naval Bronze	<input type="checkbox"/>
	<input type="checkbox"/> PNB: Polished Nickel	<input type="checkbox"/> DBP: Dark Bronze	<input type="checkbox"/> SGA: Satin Gold	<input type="checkbox"/>
	<input type="checkbox"/> AZB: Antique Bronze	<input type="checkbox"/> LBP: Light Bronze	<input type="checkbox"/> SBA: Satin Bronze	<input type="checkbox"/>
	<input type="checkbox"/> SZB: Satin Bronze	<input type="checkbox"/> MGP: Medium Gold	<input type="checkbox"/> ORA: Oil Rubbed Bronze	<input type="checkbox"/>
	<input type="checkbox"/> PZB: Polished Bronze	<input type="checkbox"/> SCP: Sponged Copper	<input type="checkbox"/> SCA: Satin Copper	<input type="checkbox"/>
	<input type="checkbox"/> CSB: Custom Brass*	<input type="checkbox"/> CSP: Custom Paint*	<input type="checkbox"/> CSA: Custom Aluminum*	<input type="checkbox"/> CSS: Custom SS*

OPTIONS	<input type="checkbox"/> L211: 2-11wCLED Uplight	<input type="checkbox"/> DIM: Dimming Driver (std)	<input type="checkbox"/> SPR: Surge Protector
	<input type="checkbox"/> L213: 2-13wCLED Uplight	<input type="checkbox"/> IEM: Integral Emer. Ballast	<input type="checkbox"/> REM: Remote Emer. Ballast
	<input type="checkbox"/> L223: 2-23wCLED Uplight	<input type="checkbox"/> TPL: Top Lens	<input type="checkbox"/>
	<input type="checkbox"/>	<input type="checkbox"/>	<input type="checkbox"/>
	<input type="checkbox"/>	<input type="checkbox"/>	<input type="checkbox"/>