



# Beatriz

## SC-7700~SC-7711

Our Beatriz fixtures are really just works of art in the guise of commercial light fixtures. We hand blow each piece of glass and then shape it to lock into the metal fitter at top. During the blowing process we are constantly dipping it into cooling water to install fractures into the molten glass shape. Lots of heat and steam involved in this process make for a one of a kind product that is as timeless as it is beautiful (as the name implies). We are happy to be able to offer these fixtures as a standard item in our portfolio and hope there are many places that need something so unique.

### ~Beatriz Series~

- Chandelier: CH-7700~CH-7711
- Pendant: PD-7700~PD-7731
- Ceiling Mount: CL-7700~CL-7708
- Wall Mount: SC-7700~SC-7711
- Bollard: BL-7700~BL-7711

**Mounting:** Lightsmith fixtures mount to standard 4" octagon electrical boxes unless otherwise specified. All hardware and canopies supplied.

**Listing and Warranty:** Lightsmith fixtures are Underwriters Laboratories listed and carry a standard three year warranty against defects in materials and labor beginning at date of shipment.



## Fixture Specifications

SC-77__	~	DIFFUSER	~	METAL FINISH	~	VOLTAGE	~	NR	~	OPTIONS	~	MODIFICATIONS
(Example: SC-7700)		(Example: WVG)		(Example: ABB)		(120V) (277V) (347V)		STEM=S+Lgth (Example:S-96") CHAIN=C+Lgth (Example:C-96") NR=Not required		(Example: DIM, IEM)		(Example: Custom Paint) Use "Notes" Box At Top To Explain Modifications

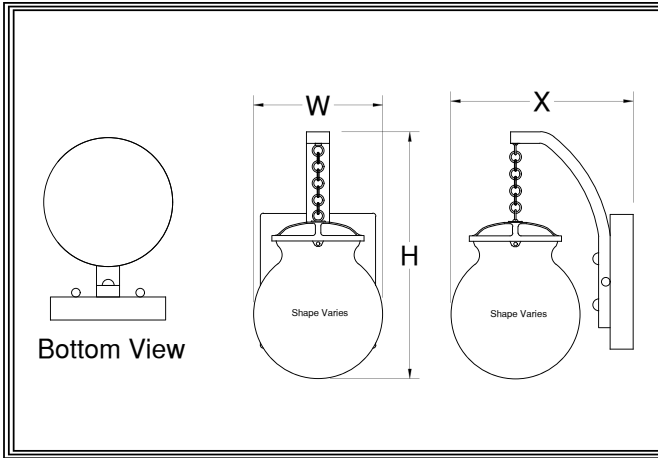

SC-77__	
Fixture Number	Job Type
Job Name	

### Notes~Modifications

	Fixture Number	Dimensions	Lamping	Weight	Options
LED	<input type="checkbox"/> SC-7709	8w x 15h x 10x	1-13wLLED (1410 lumens)	10 lbs	WLM
	<input type="checkbox"/> SC-7710	10w x 22h x 12x	1-23wLLED (2790 lumens)	12 lbs	WLM
	<input type="checkbox"/> SC-7711	12w x 29h x 14x	1-38wLLED (5734 lumens)	16 lbs	WLM REM, SPR**
INCANDESCENT	<input type="checkbox"/> SC-7700	8w x 15h x 10x	1-60wA (800 lumens)	9 lbs	WLM
	<input type="checkbox"/> SC-7701	10w x 22h x 12x	1-100wA (1740 lumens)	11 lbs	WLM
	<input type="checkbox"/> SC-7702	12w x 29h x 14x	1-150wA (2680 lumens)	15 lbs	WLM

~Single Circuit Standard Wiring~

\*\*All LED Fixtures

DIFFUSER	<input type="checkbox"/> <b>WVG:</b> Water Veined Glass		<input type="checkbox"/> <b>ECH:</b> Etched* <i>*Etched option creates a matte, non-glossy finish on one side of the diffuser. (Example: WOA-ECH)</i>
----------	---	--	--

	SOLID BRASS FINISHES	PAINTED METAL FINISHES	ALUMINUM FINISHES	STAINLESS STEEL FINISHES
METAL FINISH	<input type="checkbox"/> <b>ABB:</b> Antique Brass	<input type="checkbox"/> <b>DGP:</b> Dark Green	<input type="checkbox"/> <b>SAA:</b> Satin Aluminum	<input type="checkbox"/> <b>NA</b>
	<input type="checkbox"/> <b>SBB:</b> Satin Brass	<input type="checkbox"/> <b>VGP:</b> Verde Green	<input type="checkbox"/> <b>SNA:</b> Satin Nickel	<input type="checkbox"/>
	<input type="checkbox"/> <b>PBB:</b> Polished Brass	<input type="checkbox"/> <b>CGP:</b> Charcoal Gray	<input type="checkbox"/> <b>PAA:</b> Polished Aluminum	<input type="checkbox"/>
	<input type="checkbox"/> <b>ANB:</b> Antique Nickel	<input type="checkbox"/> <b>MBP:</b> Medium Bronze	<input type="checkbox"/> <b>BBA:</b> Burnished Bronze	<input type="checkbox"/>
	<input type="checkbox"/> <b>SNB:</b> Satin Nickel	<input type="checkbox"/> <b>SBP:</b> Satin Black	<input type="checkbox"/> <b>RNA:</b> Red Naval Bronze	<input type="checkbox"/>
	<input type="checkbox"/> <b>PNB:</b> Polished Nickel	<input type="checkbox"/> <b>DBP:</b> Dark Bronze	<input type="checkbox"/> <b>SGA:</b> Satin Gold	<input type="checkbox"/>
	<input type="checkbox"/> <b>AZB:</b> Antique Bronze	<input type="checkbox"/> <b>LBP:</b> Light Bronze	<input type="checkbox"/> <b>SBA:</b> Satin Bronze	<input type="checkbox"/>
	<input type="checkbox"/> <b>SZB:</b> Satin Bronze	<input type="checkbox"/> <b>MGP:</b> Medium Gold	<input type="checkbox"/> <b>ORA:</b> Oil Rubbed Bronze	<input type="checkbox"/>
	<input type="checkbox"/> <b>PZB:</b> Polished Bronze	<input type="checkbox"/> <b>SCP:</b> Sponged Copper	<input type="checkbox"/> <b>SCA:</b> Satin Copper	<input type="checkbox"/>
	<input type="checkbox"/> <b>CSB:</b> Custom Brass*	<input type="checkbox"/> <b>CSP:</b> Custom Paint*	<input type="checkbox"/> <b>CSA:</b> Custom Aluminum*	<input type="checkbox"/>

OPTIONS	<input type="checkbox"/> <b>REM:</b> Remote Emer. Ballast	<input type="checkbox"/> <b>DIM:</b> Dimming Driver (std) <input type="checkbox"/> <b>WLM:</b> Wet Location Mounting	<input type="checkbox"/> <b>SPR:</b> Surge Protector
---------	---	---	--