



# Bossajin

## SC-2900~SC-2911

Our Bossajin fixtures are the "Plain Jane" bowls of all our Lightsmith creations. They are hard working and cheap to keep! Solid brass or aluminum trim ring spinnings hold a shallow acrylic bowl. A simple, straight-lined support stem handles the weight for the pendant and chandelier versions. No unnecessary ornamentation...just what it takes to make things work and nothing more. Bossajin lights come in amazing metal finishes with a variety of acrylic choices. Be daring and try our Purple Haze faux alabaster! Or be smart and try our LED options.

### ~Bossajin Series~

- Chandelier: CH-2900~CH-2911
- Pendant: PD-2900~PD-2931
- Ceiling Mount: CL-2900~CL-2908
- Wall Mount: SC-2900~SC-2911
- Bollard: BL-2900~BL-2911

**Mounting:** Lightsmith fixtures mount to standard 4" octagon electrical boxes unless otherwise specified. All hardware and canopies supplied.

**Listing and Warranty:** Lightsmith fixtures are Underwriters Laboratories listed and carry a standard three year warranty against defects in materials and labor beginning at date of shipment.



## Fixture Specifications

SC-29	~	DIFFUSER (Example: BGA-ECH)	~	METAL FINISH (Example: ABB)	~	VOLTAGE <input type="checkbox"/> (120V) <input type="checkbox"/> (277V) <input type="checkbox"/> (347V)	~	NR STEM=S+Lgth (Example: S-96") CHAIN=C+Lgth (Example: C-96") NR=Not required	~	OPTIONS (Example: DIM,IEM)	~	MODIFICATIONS (Example: Custom Paint) Use "Notes" Box At Top To Explain Modifications
-------	---	--------------------------------	---	--------------------------------	---	--	---	--	---	-------------------------------	---	---

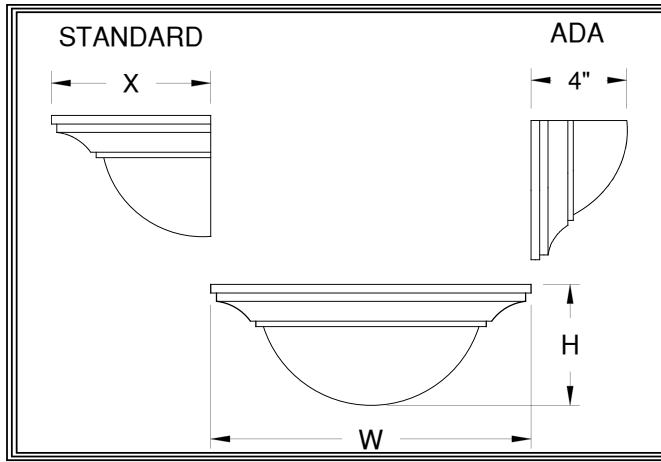

SC-29

Fixture Number      Job Type

---

Job Name

Notes~Modifications

	Fixture Number	Dimensions	Lamping	Weight	Options
LED	<input type="checkbox"/> SC-2909	16w x 6h x 4x*	2-13wLED (2820 lumens)	6 lbs	L211,TPL
	<input type="checkbox"/> SC-2910	20w x 8h x 10x	3-13wLED (4230 lumens)	8 lbs	L213,IEM,TPL
	<input type="checkbox"/> SC-2911	24w x 10h x 12x	4-13wLED (5640 lumens)	10 lbs	L223,IEM,TPL DALI,REM,FUS**
INCANDESCENT	<input type="checkbox"/> SC-2900	16w x 6h x 4x*	2-60wA (1600 lumens)	3 lbs	TPL
	<input type="checkbox"/> SC-2901	20w x 8h x 10x	3-60wA (2400 lumens)	5 lbs	TPL
	<input type="checkbox"/> SC-2902	24w x 10h x 12x	4-60wA (3200 lumens)	7 lbs	TPL
FLUORESCENT	<input type="checkbox"/> SC-2903	16w x 6h x 4x*	2-18wCFQ (2400 lumens)	5 lbs	L211,TPL
	<input type="checkbox"/> SC-2904	20w x 8h x 10x	2-32wCFT (4800 lumens)	7 lbs	L213,IEM,TPL
	<input type="checkbox"/> SC-2905	24w x 10h x 12x	2-42wCFT (6400 lumens)	9 lbs	L223,IEM,TPL DIM,REM,FUS*

\*ADA Fixture

~Single Circuit Standard Wiring~

\*All Fluorescent Fixtures  
\*\*All LED Fixtures

	DIFFUSER	DIFFUSER	DIFFUSER
DIFFUSER	<input type="checkbox"/> BGA: Beige Alabaster Acrylic	<input type="checkbox"/> GRA: Green Edge Acrylic	<input type="checkbox"/> ECH: Etched*
	<input type="checkbox"/> NHA: Natural Horn Acrylic	<input type="checkbox"/> EGA: Earth Green Acrylic	*Etched option creates a matte, non-glossy finish on one side of the diffuser. (Example: WOA-ECH)
	<input type="checkbox"/> WHA: White Alabaster Acrylic	<input type="checkbox"/> DGA: Deep Gold Acrylic	
	<input type="checkbox"/> HNA: Honey Alabaster Acrylic	<input type="checkbox"/> SBA: Sea Blue Acrylic	
	<input type="checkbox"/> WOA: White Opal Acrylic	<input type="checkbox"/> PHA: Purple Haze Acrylic	

	SOLID BRASS FINISHES	PAINTED METAL FINISHES	ALUMINUM FINISHES	STAINLESS STEEL FINISHES
METAL FINISH	<input type="checkbox"/> ABB: Antique Brass	<input type="checkbox"/> DGP: Dark Green	<input type="checkbox"/> SAA: Satin Aluminum	<input type="checkbox"/> SSS: Satin
	<input type="checkbox"/> SBB: Satin Brass	<input type="checkbox"/> VGP: Verde Green	<input type="checkbox"/> SNA: Satin Nickel	<input type="checkbox"/> DSS: Distressed
	<input type="checkbox"/> PBB: Polished Brass	<input type="checkbox"/> CGP: Charcoal Gray	<input type="checkbox"/> PAA: Polished Aluminum	<input type="checkbox"/> PSS: Polished
	<input type="checkbox"/> ANB: Antique Nickel	<input type="checkbox"/> MBP: Medium Bronze	<input type="checkbox"/> BBA: Burnished Bronze	<input type="checkbox"/> HSS: Hammered
	<input type="checkbox"/> SNB: Satin Nickel	<input type="checkbox"/> SBP: Satin Black	<input type="checkbox"/> RNA: Red Naval Bronze	<input type="checkbox"/>
	<input type="checkbox"/> PNB: Polished Nickel	<input type="checkbox"/> DBP: Dark Bronze	<input type="checkbox"/> SGA: Satin Gold	<input type="checkbox"/>
	<input type="checkbox"/> AZB: Antique Bronze	<input type="checkbox"/> LBP: Light Bronze	<input type="checkbox"/> SBA: Satin Bronze	<input type="checkbox"/>
	<input type="checkbox"/> SZB: Satin Bronze	<input type="checkbox"/> MGP: Medium Gold	<input type="checkbox"/> ORA: Oil Rubbed Bronze	<input type="checkbox"/>
	<input type="checkbox"/> PZB: Polished Bronze	<input type="checkbox"/> SCP: Sponged Copper	<input type="checkbox"/> SCA: Satin Copper	<input type="checkbox"/>
	<input type="checkbox"/> CSB: Custom Brass*	<input type="checkbox"/> CSP: Custom Paint*	<input type="checkbox"/> CSA: Custom Aluminum*	<input type="checkbox"/>
	<input type="checkbox"/>			<input type="checkbox"/>
	<input type="checkbox"/>			<input type="checkbox"/>
	<input type="checkbox"/>			<input type="checkbox"/>
	<input type="checkbox"/>			<input type="checkbox"/>

	OPTIONS	OPTIONS	OPTIONS
OPTIONS	<input type="checkbox"/> L211: 2-11wCLED Uplight	<input type="checkbox"/> DIM: Dimming Ballast	<input type="checkbox"/> FUS: Fusing
	<input type="checkbox"/> L213: 2-13wCLED Uplight	<input type="checkbox"/> IEM: Integral Emer. Ballast	<input type="checkbox"/> DALI: Dali dimming LED
	<input type="checkbox"/> L223: 2-23wCLED Uplight	<input type="checkbox"/> TPL: Top Lens	<input type="checkbox"/> REM: Remote Emer. Ballast
	<input type="checkbox"/>	<input type="checkbox"/>	<input type="checkbox"/>
	<input type="checkbox"/>	<input type="checkbox"/>	<input type="checkbox"/>
	<input type="checkbox"/>	<input type="checkbox"/>	<input type="checkbox"/>