



Guildford

EX-1900~EX-1911

Our Guildford fixtures are an exact copy of an early 1900's cast iron torchiere. We guessed it was made somewhere about 1916 because of the paint finish and the early machine screw threads used to put it together. (Things you notice when duplicating metal castings!) We can make this fixture in iron, but we cannot pour iron in the shop, only aluminum and brass. So it is up to our customers to make the call. These are beautiful castings with much architectural detail...egg and darts blending with acanthus leaves, fasces wraps in center. Classic and Period Americana for sure.

~Guildford Series~

Wall Mt: EX-1900~EX-1901

Mounting: Lightsmith fixtures mount to standard 4" octagon electrical boxes unless otherwise specified. All hardware and canopies supplied.

Listing and Warranty: Lightsmith fixtures are Underwriters Laboratories listed and carry a standard three year warranty against defects in materials and labor beginning at date of shipment.



Fixture Specifications

EX-19 ~ WOG ~ _____ ~ _____ ~ NR ~ _____ ~ _____

FIXTURE NUMBER (Example: EX-1900)
 DIFFUSER (Example: WOG)
 METAL FINISH (Example: ABB)
 VOLTAGE
 (120V)
 (277V)
 (347V)
 STEM=S+Lgth (Example: S-96")
 CHAIN=C+Lgth (Example: C-96")
 NR=Not required
 OPTIONS (Example: SPR)
 MODIFICATIONS (Example: Custom Paint*)
 Use "Notes" Box At Top To Explain Modifications

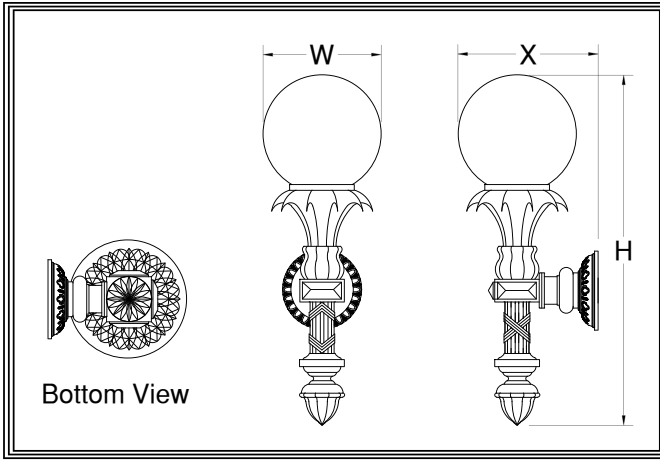

EX-19 _____
 Fixture Number Job Type

Job Name

Notes~Modifications

	Fixture Number	Dimensions	Lamping	Weight	Options
LED	<input type="checkbox"/> EX-1900	16w x 48h x 19x	1-23wLED (2790 lumens)	70 lbs	WLM REM,SPR**
INCANDESCENT	<input type="checkbox"/> EX-1901	16w x 48h x 19x	1-100wA (1740 lumens)	70 lbs	WLM
FLUORESCENT	<input type="checkbox"/>				

~Single Circuit Standard Wiring~

**All LED Fixtures

WOG: White Opal Glass
 ECH: Etched*
**Etched option creates a matte, non-glossy finish on one side of the diffuser. (Example: WOA-ECH)*

	SOLID BRASS FINISHES	PAINTED METAL FINISHES	ALUMINUM FINISHES	STAINLESS STEEL FINISHES
METAL FINISH	<input type="checkbox"/> ABB: Antique Brass <input type="checkbox"/> SBB: Satin Brass <input type="checkbox"/> PBB: Polished Brass <input type="checkbox"/> ANB: Antique Nickel <input type="checkbox"/> SNB: Satin Nickel <input type="checkbox"/> PNB: Polished Nickel <input type="checkbox"/> AZB: Antique Bronze <input type="checkbox"/> SZB: Satin Bronze <input type="checkbox"/> PZB: Polished Bronze <input type="checkbox"/> CSB: Custom Brass*	<input type="checkbox"/> DGP: Dark Green <input type="checkbox"/> VGP: Verde Green <input type="checkbox"/> CGP: Charcoal Gray <input type="checkbox"/> MBP: Medium Bronze <input type="checkbox"/> SBP: Satin Black <input type="checkbox"/> DBP: Dark Bronze <input type="checkbox"/> LBP: Light Bronze <input type="checkbox"/> MGP: Medium Gold <input type="checkbox"/> SCP: Sponged Copper <input type="checkbox"/> CSP: Custom Paint*	<input type="checkbox"/> SAA: Satin Aluminum <input type="checkbox"/> SNA: Satin Nickel <input type="checkbox"/> PAA: Polished Aluminum <input type="checkbox"/> BBA: Burnished Bronze <input type="checkbox"/> RNA: Red Naval Bronze <input type="checkbox"/> SGA: Satin Gold <input type="checkbox"/> SBA: Satin Bronze <input type="checkbox"/> ORA: Oil Rubbed Bronze <input type="checkbox"/> SCA: Satin Copper <input type="checkbox"/> CSA: Custom Aluminum*	<input type="checkbox"/> NA

REM: Remote Emer.Ballast*
 SPR: Surge protector
 WLM: Wet Location Mtg