



D'sandre

CL-1700~CL-1708

Our D'sandre fixtures are just fine architectural masterpieces meant for mounting in state and federal buildings. They also look just right in classic university settings and historic public places. The octagonal pendants are filled with classical motifs. You will see greek key moldings at top leading from the colonial cornices down into true ribbon and stick fascias designs that border the diffuser panels top and bottom. Deeply embossed egg and dart trim repeats top, center, and bottom. We build D'sandre in a variety of styles. D'sandre can be a sconce, ceiling, chandelier, etc.

~D'sandre Series~

Chandelier: CH-1700~CH-1711

Pendant: PD-1700~PD-1731

Ceiling Mt: CL-1700~CL-1708

Wall Mt: SC-1700~SC-1711

Bollard: BL-1700~BL-1711

Mounting: Lightsmith fixtures mount to standard 4" octagon electrical boxes unless otherwise specified. All hardware and canopies supplied.

Listing and Warranty: Lightsmith fixtures are Underwriters Laboratories listed and carry a standard three year warranty against defects in materials and labor beginning at date of shipment.



Fixture Specifications

CL-17__

FIXTURE NUMBER
(Example: CL-1702)

~

DIFFUSER
(Example: BGA-ECH)

~

METAL FINISH
(Example: ABB)

~

VOLTAGE
 (120V)
 (277V)
 (347V)

~

NR

STEM=S+Lgth
(Example: S-96")
CHAIN=C+Lgth
(Example: C-96")
NR=Not required

~

OPTIONS
(Example: DIM, REM)

~

MODIFICATIONS
(Example: Custom Paint)
Use "Notes" Box At Top To Explain Modifications

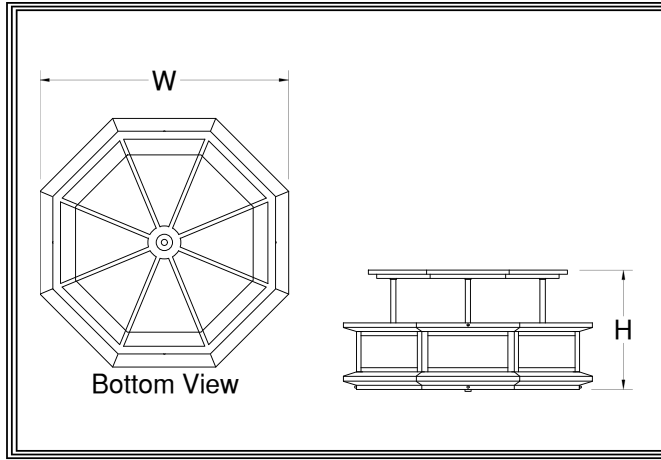

CL-17__

Fixture Number

Job Type

Job Name

Notes~Modifications

	Fixture Number	Dimensions	Lamping	Weight	Options
LED	<input type="checkbox"/> CL-1706	18w x 10h	4-11wCLED (4768 lm)	16 lbs	REM,IEM,SPR**
	<input type="checkbox"/> CL-1707	24w x 12h	6-13wCLED (8560 lm)	24 lbs	DIM,WLM
	<input type="checkbox"/> CL-1708	36w x 14h	6-23wCLED (16740 lm)	38 lbs	DIM,WLM
INCANDESCENT	<input type="checkbox"/> CL-1700	18w x 10h	3-60wA (2400 lm)	13 lbs	WLM
	<input type="checkbox"/> CL-1701	24w x 12h	6-60wA (4800 lm)	21 lbs	WLM
	<input type="checkbox"/> CL-1702	36w x 14h	12-60wA (9600 lm)	34 lbs	WLM
FLUORESCENT	<input type="checkbox"/>				

~Single Circuit Standard Wiring~

**All LED Fixtures

DIFFUSER	<input type="checkbox"/> BGA: Beige Alabaster Acrylic	<input type="checkbox"/> GRA: Green Edge Acrylic	<input type="checkbox"/> ECH: Etched*
	<input type="checkbox"/> NHA: Natural Horn Acrylic	<input type="checkbox"/> EGA: Earth Green Acrylic	*Etched option creates a matte, non-glossy finish on one side of the diffuser. (Example: WOA-ECH)
	<input type="checkbox"/> WHA: White Alabaster Acrylic	<input type="checkbox"/> DGA: Deep Gold Acrylic	
	<input type="checkbox"/> HNA: Honey Alabaster Acrylic	<input type="checkbox"/> SBA: Sea Blue Acrylic	
	<input type="checkbox"/> WOA: White Opal Acrylic	<input type="checkbox"/> PHA: Purple Haze Acrylic	

	SOLID BRASS FINISHES	PAINTED METAL FINISHES	ALUMINUM FINISHES	STAINLESS STEEL FINISHES
METAL FINISH	<input type="checkbox"/> ABB: Antique Brass	<input type="checkbox"/> DGP: Dark Green	<input type="checkbox"/> SAA: Satin Aluminum	<input type="checkbox"/> SSS: Satin
	<input type="checkbox"/> SBB: Satin Brass	<input type="checkbox"/> VGP: Verde Green	<input type="checkbox"/> SNA: Satin Nickel	<input type="checkbox"/> DSS: Distressed
	<input type="checkbox"/> PBB: Polished Brass	<input type="checkbox"/> CGP: Charcoal Gray	<input type="checkbox"/> PAA: Polished Aluminum	<input type="checkbox"/> PSS: Polished
	<input type="checkbox"/> ANB: Antique Nickel	<input type="checkbox"/> MBP: Medium Bronze	<input type="checkbox"/> BBA: Burnished Bronze	<input type="checkbox"/> HSS: Hammered
	<input type="checkbox"/> SNB: Satin Nickel	<input type="checkbox"/> SBP: Satin Black	<input type="checkbox"/> RNA: Red Naval Bronze	<input type="checkbox"/>
	<input type="checkbox"/> PNB: Polished Nickel	<input type="checkbox"/> DBP: Dark Bronze	<input type="checkbox"/> SGA: Satin Gold	<input type="checkbox"/>
	<input type="checkbox"/> AZB: Antique Bronze	<input type="checkbox"/> LBP: Light Bronze	<input type="checkbox"/> SBA: Satin Bronze	<input type="checkbox"/>
	<input type="checkbox"/> SZB: Satin Bronze	<input type="checkbox"/> MGP: Medium Gold	<input type="checkbox"/> ORA: Oil Rubbed Bronze	<input type="checkbox"/>
	<input type="checkbox"/> PZB: Polished Bronze	<input type="checkbox"/> SCP: Sponged Copper	<input type="checkbox"/> SCA: Satin Copper	<input type="checkbox"/>
	<input type="checkbox"/> CSB: Custom Brass*	<input type="checkbox"/> CSP: Custom Paint*	<input type="checkbox"/> CSA: Custom Aluminum*	<input type="checkbox"/>
				<input type="checkbox"/> CSS: Custom SS*

OPTIONS	<input type="checkbox"/> IEM: Integral Emer. Driver	<input type="checkbox"/> DIM: Dimming Driver (std)	<input type="checkbox"/> SPR: Surge Protector
	<input type="checkbox"/> REM: Remote Emer. Driver	<input type="checkbox"/>	<input type="checkbox"/> WLM: Wet Location Mounting
	<input type="checkbox"/>	<input type="checkbox"/>	<input type="checkbox"/>
	<input type="checkbox"/>	<input type="checkbox"/>	<input type="checkbox"/>