



Tristan

CL-1500~CL-1508

Our Tristan fixtures feature seamless bowls and sconces combining contemporary clean looks with a splash of classic styling in the rings and support assemblies. Metal finishes will run from bright solid brasses to dark powdercoats on top of an aluminum frame. The effects can be quite dramatic when put into the context of a traditional or contemporary styled environment. We recommend the top lens options where available. And please consider our CFL and LED lamping options. You will find that our 50,000 hour LED's will make your maintenance guys totally joyous!

~Tristan Series~

- Chandelier: CH-1500~CH-1511
- Pendant: PD-1500~PD-1531
- Ceiling Mt: CL-1500~CL-1508
- Wall Mt: SC-1500~SC-1511
- Bollard: BL-1500~BL-1511

Mounting: Lightsmith fixtures mount to standard 4" octagon electrical boxes unless otherwise specified. All hardware and canopies supplied.

Listing and Warranty: Lightsmith fixtures are Underwriters Laboratories listed and carry a standard three year warranty against defects in materials and labor beginning at date of shipment.



Fixture Specifications

CL-15 <small>FIXTURE NUMBER (Example: CL-1502)</small>	~	<small>DIFFUSER (Example: BGA-ECH)</small>	~	<small>METAL FINISH (Example: ABB)</small>	~	<small>VOLTAGE</small> <input type="checkbox"/> (120V) <input type="checkbox"/> (277V) <input type="checkbox"/> (347V)	~	NR <small>STEM=S+Lgth (Example:S-96") CHAIN=C+Lgth (Example:C-96") NR=Not required</small>	~	<small>OPTIONS (Example: DIM, REM)</small>	~	<small>MODIFICATIONS (Example: Custom Paint) Use "Notes" Box At Top To Explain Modifications</small>
--	---	--	---	--	---	---	---	--	---	--	---	---

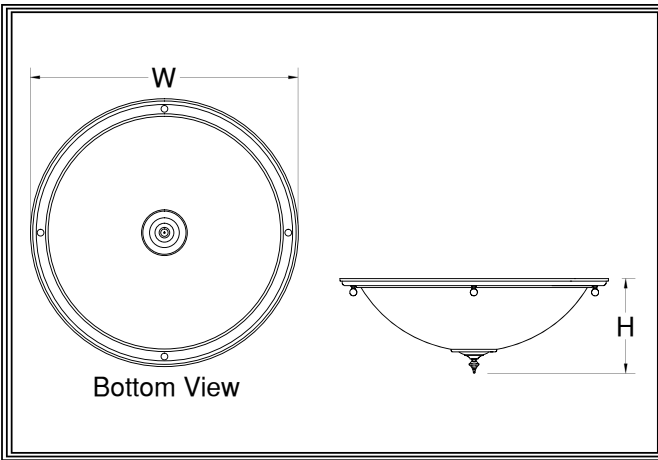

CL-15

Fixture Number Job Type

Job Name

Notes~Modifications

	Fixture Number	Dimensions	Lamping	Weight	Options
LED	<input type="checkbox"/> CL-1506	18w x 8h	4-11wCLED	11 lbs	DALI,IEM,FUS**
	<input type="checkbox"/> CL-1507	26w x 10h	6-13wCLED	13 lbs	BFL,WLM
	<input type="checkbox"/> CL-1508	38w x 12h	6-23wCLED	18 lbs	BFL,WLM
INCANDESCENT	<input type="checkbox"/> CL-1500	18w x 8h	3-60wA	8 lbs	BFL,WLM
	<input type="checkbox"/> CL-1501	26w x 10h	6-60wA	10 lbs	BFL,WLM
	<input type="checkbox"/> CL-1502	38w x 12h	12-60wA	14 lbs	BFL,WLM
FLUORESCENT	<input type="checkbox"/> CL-1503	18w x 8h	2-26wCFT	10 lbs	DIM,IEM,FUS*
	<input type="checkbox"/> CL-1504	26w x 10h	4-32wCFT	12 lbs	BFL,WLM
	<input type="checkbox"/> CL-1505	38w x 12h	6-42wCFT	17 lbs	BFL,WLM

~Single Circuit Standard Wiring~

*All Fluorescent Fixtures
**All LED Fixtures

DIFFUSER	<input type="checkbox"/> BGA: Beige Alabaster Acrylic	<input type="checkbox"/> GRA: Green Edge Acrylic	<input type="checkbox"/> ECH: Etched*
	<input type="checkbox"/> NHA: Natural Horn Acrylic	<input type="checkbox"/> EGA: Earth Green Acrylic	*Etched option creates a matte, non-glossy finish on one side of the diffuser. (Example: WOA-ECH)
	<input type="checkbox"/> WHA: White Alabaster Acrylic	<input type="checkbox"/> DGA: Deep Gold Acrylic	
	<input type="checkbox"/> HNA: Honey Alabaster Acrylic	<input type="checkbox"/> SBA: Sea Blue Acrylic	
	<input type="checkbox"/> WOA: White Opal Acrylic	<input type="checkbox"/> PHA: Purple Haze Acrylic	

	SOLID BRASS FINISHES	PAINTED METAL FINISHES	ALUMINUM FINISHES	STAINLESS STEEL FINISHES
METAL FINISH	<input type="checkbox"/> ABB: Antique Brass	<input type="checkbox"/> DGP: Dark Green	<input type="checkbox"/> SAA: Satin Aluminum	<input type="checkbox"/> SSS: Satin
	<input type="checkbox"/> SBB: Satin Brass	<input type="checkbox"/> VGP: Verde Green	<input type="checkbox"/> SNA: Satin Nickel	<input type="checkbox"/> DSS: Distressed
	<input type="checkbox"/> PBB: Polished Brass	<input type="checkbox"/> CGP: Charcoal Gray	<input type="checkbox"/> PAA: Polished Aluminum	<input type="checkbox"/> PSS: Polished
	<input type="checkbox"/> ANB: Antique Nickel	<input type="checkbox"/> MBP: Medium Bronze	<input type="checkbox"/> BBA: Burnished Bronze	<input type="checkbox"/> HSS: Hammered
	<input type="checkbox"/> SNB: Satin Nickel	<input type="checkbox"/> SBP: Satin Black	<input type="checkbox"/> RNA: Red Naval Bronze	<input type="checkbox"/>
	<input type="checkbox"/> PNB: Polished Nickel	<input type="checkbox"/> DBP: Dark Bronze	<input type="checkbox"/> SGA: Satin Gold	<input type="checkbox"/>
	<input type="checkbox"/> AZB: Antique Bronze	<input type="checkbox"/> LBP: Light Bronze	<input type="checkbox"/> SBA: Satin Bronze	<input type="checkbox"/>
	<input type="checkbox"/> SZB: Satin Bronze	<input type="checkbox"/> MGP: Medium Gold	<input type="checkbox"/> ORA: Oil Rubbed Bronze	<input type="checkbox"/>
	<input type="checkbox"/> PZB: Polished Bronze	<input type="checkbox"/> SCP: Sponged Copper	<input type="checkbox"/> SCA: Satin Copper	<input type="checkbox"/>
	<input type="checkbox"/> CSB: Custom Brass*	<input type="checkbox"/> CSP: Custom Paint*	<input type="checkbox"/> CSA: Custom Aluminum*	<input type="checkbox"/> CSS: Custom SS*
	<input type="checkbox"/>			<input type="checkbox"/>
	<input type="checkbox"/>			<input type="checkbox"/>
	<input type="checkbox"/>			<input type="checkbox"/>
	<input type="checkbox"/>			<input type="checkbox"/>

OPTIONS	<input type="checkbox"/> IEM: Integral Emer. Ballast	<input type="checkbox"/> BFL: Bottom Finial	<input type="checkbox"/> FUS: Fusing
	<input type="checkbox"/> DIM: Dimming Ballast	<input type="checkbox"/>	<input type="checkbox"/> REM: Remote Emer. Ballast
	<input type="checkbox"/>	<input type="checkbox"/>	<input type="checkbox"/> DALI: Dali dimming LED
	<input type="checkbox"/>	<input type="checkbox"/>	<input type="checkbox"/> WLM: Wet Location Mounting
	<input type="checkbox"/>	<input type="checkbox"/>	<input type="checkbox"/>