



Vigo

CL-12400~CL-12408

Our Vigo fixtures are modern drum types that look good in just about every location. They look just as right in a contemporary office space as they would in an adaptive reuse warehouse...or maybe a castle. These lights are blends of surrounding rolled metal rings and extra large central spinnings. Pendants feature a bottom spread lens and a nice cable/stem suspension system. The effect of Vigo fixtures is a smooth ambience in the places they inhabit. Nice over dining tables. Nice over library tables. Not quite bright enough for operating tables. But you get the point. Nice lights.

~Vigo Series~

Chandelier: CH-12400~CH-12411

Pendant: PD-12400~PD-12421

Ceiling Mt: CL-12400~CL-12408

Wall Mt: SC-12400~SC-12411

Bollard: BL-12400~BL-12411

Mounting: Lightsmith fixtures mount to standard 4" octagon electrical boxes unless otherwise specified. All hardware and canopies supplied.

Listing and Warranty: Lightsmith fixtures are Underwriters Laboratories listed and carry a standard three year warranty against defects in materials and labor beginning at date of shipment.



Fixture Specifications

CL-124
FIXTURE NUMBER
(Example: CL-12402)

~
DIFFUSER
(Example: WOA)

~
METAL FINISH
(Example: ABB)

~
VOLTAGE
 (120V)
 (277V)
 (347V)

~
NR
STEM=S+Lgth
(Example: S-96")
CHAIN=C+Lgth
(Example: C-96")
NR=Not required

~
OPTIONS
(Example: DIM, REM)

~
MODIFICATIONS
(Example: Custom Paint*)
Use "Notes" Box At Top To Explain Modifications

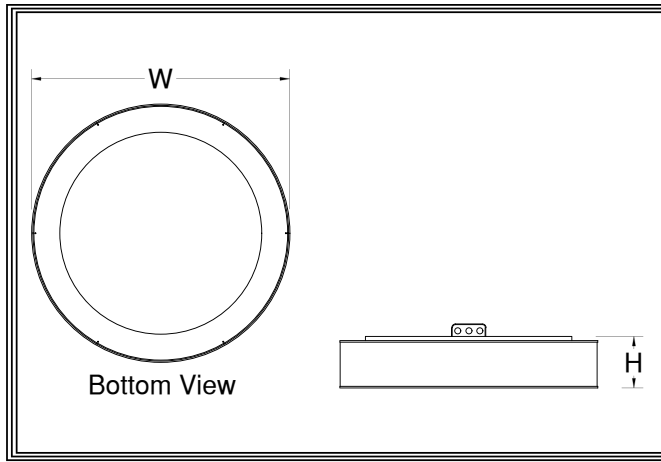

CL-124__
Fixture Number Job Type

Job Name

Notes~Modifications

	Fixture Number	Dimensions	Lamping	Weight	Options
LED	<input type="checkbox"/> CL-12406	15w x 4h	4-13wLLED (5640 lm)	16 lbs	REM,IEM,SPR**
	<input type="checkbox"/> CL-12407	22w x 5h	6-13wLLED (8460 lm)	22 lbs	
	<input type="checkbox"/> CL-12408	33w x 6h	8-13wLLED (11280 lm)	34 lbs	
INCANDESCENT	<input type="checkbox"/> CL-12400	15w x 4h	6-60wA19 (4800 lm)	14 lbs	
	<input type="checkbox"/> CL-12401	22w x 5h	8-60wA19 (6400 lm)	20 lbs	
	<input type="checkbox"/> CL-12402	33w x 6h	10-60wA19(8000 lm)	30 lbs	
FLUORESCENT	<input type="checkbox"/>				

~Single Circuit Standard Wiring~

**All LED Fixtures

DIFFUSER	<input type="checkbox"/> BGA: Beige Alabaster Acrylic	<input type="checkbox"/> GRA: Green Edge Acrylic	<input type="checkbox"/> ECH: Etched*
	<input type="checkbox"/> NHA: Natural Horn Acrylic	<input type="checkbox"/> EGA: Earth Green Acrylic	*Etched option creates a matte, non-glossy finish on one side of the diffuser. (Example: WOA-ECH)
	<input type="checkbox"/> WHA: White Alabaster Acrylic	<input type="checkbox"/> DGA: Deep Gold Acrylic	
	<input type="checkbox"/> HNA: Honey Alabaster Acrylic	<input type="checkbox"/> WOG: White Opal Glass	
	<input type="checkbox"/> WOA: White Opal Acrylic	<input type="checkbox"/> CLG: Clear Glass	

	SOLID BRASS FINISHES	PAINTED METAL FINISHES	ALUMINUM FINISHES	STAINLESS STEEL FINISHES
METAL FINISH	<input type="checkbox"/> ABB: Antique Brass	<input type="checkbox"/> DGP: Dark Green	<input type="checkbox"/> SAA: Satin Aluminum	<input type="checkbox"/> NA:
	<input type="checkbox"/> SBB: Satin Brass	<input type="checkbox"/> VGP: Verde Green	<input type="checkbox"/> SNA: Satin Nickel	
	<input type="checkbox"/> PBB: Polished Brass	<input type="checkbox"/> CGP: Charcoal Gray	<input type="checkbox"/> PAA: Polished Aluminum	
	<input type="checkbox"/> ANB: Antique Nickel	<input type="checkbox"/> MBP: Medium Bronze	<input type="checkbox"/> BBA: Burnished Bronze	
	<input type="checkbox"/> SNB: Satin Nickel	<input type="checkbox"/> SBP: Satin Black	<input type="checkbox"/> RNA: Red Naval Bronze	
	<input type="checkbox"/> PNB: Polished Nickel	<input type="checkbox"/> DBP: Dark Bronze	<input type="checkbox"/> SGA: Satin Gold	
	<input type="checkbox"/> AZB: Antique Bronze	<input type="checkbox"/> LBP: Light Bronze	<input type="checkbox"/> SBA: Satin Bronze	
	<input type="checkbox"/> SZB: Satin Bronze	<input type="checkbox"/> MGP: Medium Gold	<input type="checkbox"/> ORA: Oil Rubbed Bronze	
	<input type="checkbox"/> PZB: Polished Bronze	<input type="checkbox"/> SCP: Sponged Copper	<input type="checkbox"/> SCA: Satin Copper	
	<input type="checkbox"/> CSB: Custom Brass*	<input type="checkbox"/> CSP: Custom Paint*	<input type="checkbox"/> CSA: Custom Aluminum*	

OPTIONS	<input type="checkbox"/> IEM: Integral Emer. Driver	<input type="checkbox"/> DIM: Dimming Driver (std)	<input type="checkbox"/> SPR: Surge Protector
	<input type="checkbox"/> REM: Remote Emer. Driver	<input type="checkbox"/>	<input type="checkbox"/>
	<input type="checkbox"/>	<input type="checkbox"/>	<input type="checkbox"/>
	<input type="checkbox"/>	<input type="checkbox"/>	<input type="checkbox"/>