



Bombay

CL-10700~CL-10708

Our Bombay fixtures are low profile drums composed of several overlapping layers of metal or acrylic. Far from being seamless as most of our designs are, the Bombay is purposefully open at the segment joints to allow just a hint of light to pass through and add to the overall "puzzle" quality of the fixtures. You still can't look inside to see the lamps, but the construction makes you want to. We build Bombay a variety of materials. We show metal sheet that has been overlapped with wood veneer in the pendant above. It is also available in a variety of acrylics as well.

~Bombay Series~

Chandelier: CH-10700~CH-10711

Pendant: PD-10700~PD-10731

Ceiling Mt: CL-10700~CL-10708

Wall Mt: SC-10700~SC-10711

Bollard: BL-10700~BL-10711

Mounting: Lightsmith fixtures mount to standard 4" octagon electrical boxes unless otherwise specified. All hardware and canopies supplied.

Listing and Warranty: Lightsmith fixtures are Underwriters Laboratories listed and carry a standard three year warranty against defects in materials and labor beginning at date of shipment.



Fixture Specifications

CL-107
FIXTURE NUMBER
(Example: CL-10702)

~
DIFFUSER
(Example: BGA-ECH)

~
METAL FINISH
(Example: ABB)

~
VOLTAGE
 (120V)
 (277V)
 (347V)

~
NR
STEM=S+Lgth
(Example: S-96")
CHAIN=C+Lgth
(Example: C-96")
NR=Not required

~
OPTIONS
(Example: DIM, REM)

~
MODIFICATIONS
(Example: Custom Paint)
Use "Notes" Box At Top To Explain Modifications

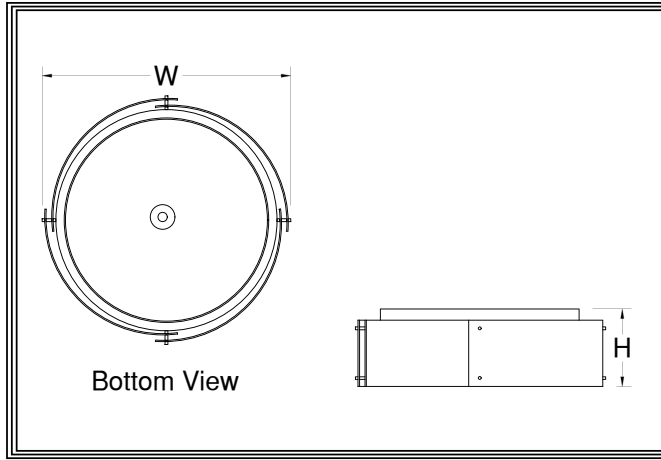

CL-107__
Fixture Number Job Type

Job Name

Notes~Modifications

	Fixture Number	Dimensions	Lamping	Weight	Options
LED	<input type="checkbox"/> CL-10706	20w x 5h	4-11wCLED	11 lbs	DALI,IEM,FUS**
	<input type="checkbox"/> CL-10707	24w x 6h	6-13wCLED	13 lbs	BFL,WLM
	<input type="checkbox"/> CL-10708	30w x 7h	6-23wCLED	18 lbs	BFL,WLM
INCANDESCENT	<input type="checkbox"/> CL-10700	20w x 5h	3-60wA	8 lbs	BFL,WLM
	<input type="checkbox"/> CL-10701	24w x 6h	6-60wA	10 lbs	BFL,WLM
	<input type="checkbox"/> CL-10702	30w x 7h	12-60wA	14 lbs	BFL,WLM
FLUORESCENT	<input type="checkbox"/> CL-10703	20w x 5h	2-26wCFT	10 lbs	DIM,IEM,FUS*
	<input type="checkbox"/> CL-10704	24w x 6h	4-32wCFT	12 lbs	BFL,WLM
	<input type="checkbox"/> CL-10705	30w x 7h	6-42wCFT	17 lbs	BFL,WLM

~Single Circuit Standard Wiring~

*All Fluorescent Fixtures

**All LED Fixtures

DIFFUSER	<input type="checkbox"/> BGA: Beige Alabaster Acrylic	<input type="checkbox"/> GRA: Green Edge Acrylic	<input type="checkbox"/> ECH: Etched*
	<input type="checkbox"/> NHA: Natural Horn Acrylic	<input type="checkbox"/> EGA: Earth Green Acrylic	*Etched option creates a matte, non-glossy finish on one side of the diffuser. (Example: WOA-ECH)
	<input type="checkbox"/> WHA: White Alabaster Acrylic	<input type="checkbox"/> DGA: Deep Gold Acrylic	
	<input type="checkbox"/> HNA: Honey Alabaster Acrylic	<input type="checkbox"/> SBA: Sea Blue Acrylic	
	<input type="checkbox"/> WOA: White Opal Acrylic	<input type="checkbox"/> PHA: Purple Haze Acrylic	

	SOLID BRASS FINISHES	PAINTED METAL FINISHES	ALUMINUM FINISHES	STAINLESS STEEL FINISHES
METAL FINISH	<input type="checkbox"/> ABB: Antique Brass	<input type="checkbox"/> DGP: Dark Green	<input type="checkbox"/> SAA: Satin Aluminum	<input type="checkbox"/> SSS: Satin
	<input type="checkbox"/> SBB: Satin Brass	<input type="checkbox"/> VGP: Verde Green	<input type="checkbox"/> SNA: Satin Nickel	<input type="checkbox"/> DSS: Distressed
	<input type="checkbox"/> PBB: Polished Brass	<input type="checkbox"/> CGP: Charcoal Gray	<input type="checkbox"/> PAA: Polished Aluminum	<input type="checkbox"/> PSS: Polished
	<input type="checkbox"/> ANB: Antique Nickel	<input type="checkbox"/> MBP: Medium Bronze	<input type="checkbox"/> BBA: Burnished Bronze	<input type="checkbox"/> HSS: Hammered
	<input type="checkbox"/> SNB: Satin Nickel	<input type="checkbox"/> SBP: Satin Black	<input type="checkbox"/> RNA: Red Naval Bronze	<input type="checkbox"/>
	<input type="checkbox"/> PNB: Polished Nickel	<input type="checkbox"/> DBP: Dark Bronze	<input type="checkbox"/> SGA: Satin Gold	<input type="checkbox"/>
	<input type="checkbox"/> AZB: Antique Bronze	<input type="checkbox"/> LBP: Light Bronze	<input type="checkbox"/> SBA: Satin Bronze	<input type="checkbox"/>
	<input type="checkbox"/> SZB: Satin Bronze	<input type="checkbox"/> MGP: Medium Gold	<input type="checkbox"/> ORA: Oil Rubbed Bronze	<input type="checkbox"/>
	<input type="checkbox"/> PZB: Polished Bronze	<input type="checkbox"/> SCP: Sponged Copper	<input type="checkbox"/> SCA: Satin Copper	<input type="checkbox"/>
	<input type="checkbox"/> CSB: Custom Brass*	<input type="checkbox"/> CSP: Custom Paint*	<input type="checkbox"/> CSA: Custom Aluminum*	<input type="checkbox"/> CSS: Custom SS*

OPTIONS	<input type="checkbox"/> IEM: Integral Emer. Ballast	<input type="checkbox"/> BFL: Bottom Finial	<input type="checkbox"/> FUS: Fusing
	<input type="checkbox"/> DIM: Dimming Ballast	<input type="checkbox"/>	<input type="checkbox"/> REM: Remote Emer. Ballast
	<input type="checkbox"/>	<input type="checkbox"/>	<input type="checkbox"/> DALI: Dali dimming LED
	<input type="checkbox"/>	<input type="checkbox"/>	<input type="checkbox"/> WLM: Wet Location Mounting
	<input type="checkbox"/>	<input type="checkbox"/>	<input type="checkbox"/>